

 **ITALIANA**[®]
f e r r a m e n t a

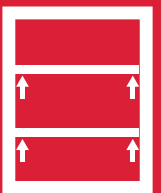

Secret Maxi



SHELF
SUPPORTS





SYMBOLS AND FINISHES LEGEND

SYMBOLS



= SHELF SAFELY LOCKED DURING TRANSPORTATION AND AT HOME.



= ANTI-TURNOVER LOCKING SYSTEM



= NORMS / PATENTS



= PHILLIPS / POZIDRIV



= WITH BUFFER



= PART NO.



= BLADE SLOT



= WITH MAGNET



= PCS. PER PACKAGE



= COMBI SLOT



= HEXAGONAL SOCKET



= NEWTON



= CAPACITY LOADING



= HEXALOBULAR SOCKET



= FRICTION



= WOOD / GLASS THICKNESS



= COUNTERSUNK HEAD



= AUTOMATIC



= HOLE DIAMETER



= PAN HEAD



= DROP DOWN



= DIAMETER



= FLANGE HEAD



= LENGTH



= FLAT HEAD



= STANDARD HINGE



= HEIGHT



= TRILOBULAR SCREW



= KIMANA HINGE



= RIGHT VERSION



= SELF-TAPPING SCREW



= FLAP HINGE



= LEFT VERSION



= EURO THREAD



= WITH SPRING



= SETTING CODE



= METRIC THREAD



= WITHOUT SPRING



= PCS. PER PAD



= PRE-INSERTED SCREW



= REVERSED SPRING



= CUT ON REQUEST



= PRE-INSERTED SCREW AND SPREADING BUSH



= SELF ADHESIVE



= WITH FLANGE

NOTE: Printing errors and omissions may exist despite our best efforts to ensure accuracy. We reserve the right to alter specifications without notice.

MATERIALS

ZA = Zinc Alloy

ST = Steel

HSS = High Speed Steel

BR = Brass

ABS = Acrylonitrile Butadiene Styrene

ZAnk = Nickel-plated Zinc Alloy

STzk = Zinc-plated Steel

AL = Aluminium

WD = Wood

EVA = Ethylene Vinyl Acetate

EP = **ENGINEERING PLASTIC**

+ **EP** = other engineering plastic available on request

SR = **SOFT RUBBER**

+ **SR** = other soft rubber available on request

EPn = Natural Engineering Plastic

EPc = Clear Engineering Plastic

SRn = Natural Soft Rubber

EPw = White Engineering Plastic

EPg = Grey Engineering Plastic

SRw = White Soft Rubber

EPwg = Water Green Engineering Plastic

SRb = Black Soft Rubber



FINISHES



= OTHER FINISHES AVAILABLE ON REQUEST

PART NO.	FINISHES	PART NO.	FINISHES	PART NO.	FINISHES
00	Insignificant finish	IF	Middle Grey	UT	T-Met 9007
AA	Natural	IJ	Light Grey	UZ	T-Met
AB	White	IL	Grey 20	WA	Bronzed
AE	White 9010	IN	Grey met. 26	WI	Burnished
EA	Black	JB	Bright Aluminium	XD	Satin-finished Steel
EC	Matt Black	JC	Aluminium - Chrome	YA	Nickel-plated
EE	Anthracite	JD	Matt Aluminium	YB	Bright Nickel-plated
EW	Grey 9007	JE	Satin-finished Aluminium	YC	Matt Nickel-plated
FU	Gunmetal	JF	Aluminium - Brass	YD	Satin-finished Nickel-plated
FV	Gunmetal V52	JG	Aluminium 5	YQ	Black Nickel
GR	Raw	JL	Aluminium PE 11	Z9	Black Zinc
HA	Brass-Plated	JM	Aluminium RAL 9006	ZA	Zinc alloy
HH	Tropicalized	KA	Chrome	ZN	Zinc-plated
HL	Raw Brass	KB	Bright Chrome	ZQ	Bright Gold
HX	Graphite	KC	Matt Chrome	ZY	Titanium
IA	Grey	NN	Metallic Beige	ZZ	Clear
IB	Metallic Grey	RO	Red		



SECRET MAXI FOR 25 mm SHELF MIN.

SECRET is a hidden shelf support which guarantees both the shelf locking and unlocking.

The shelf support SECRET is completely hidden, even when used on bifacial furniture.

The hanging system provides a structural junction between the shelf and the side panel, thus making SECRET suitable even for constructions with flap and drop-down doors.

When flap and drop-down doors are required, the shelf can be fully locked by using an exagonal key S 2,5.

The hole for the shelf locking can be drilled on either the upper or the lower side of the shelf.

SECRET allows the customer to fix and remove the shelves in an easy and intuitive way.

The furniture processing doesn't require any milling, but simple drilling operations.



INSTALLATION AND ASSEMBLING

SHELF SUPPORT INSERTION ON THE SHELF

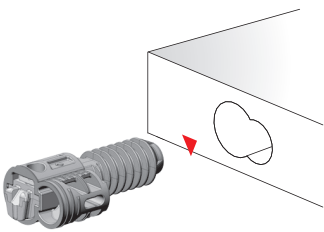

SIDE BUSH INSERTION

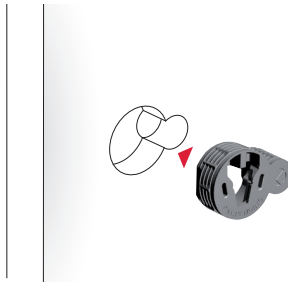

ALIGNMENT SHELF SUPPORT AND SIDE BUSH

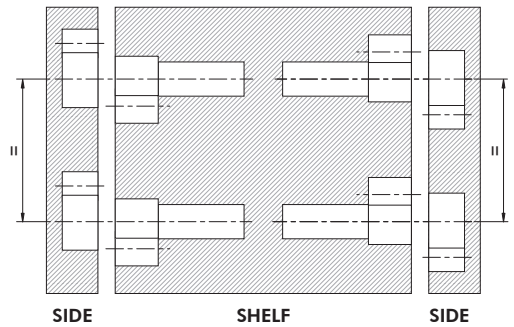

SHELF PLACEMENT

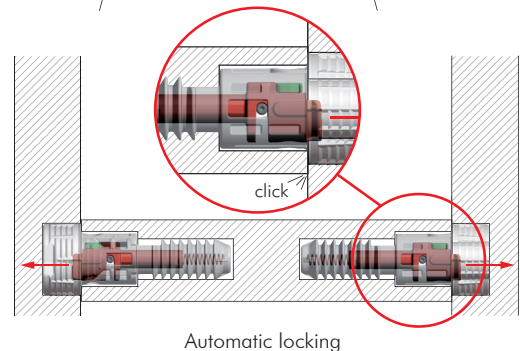
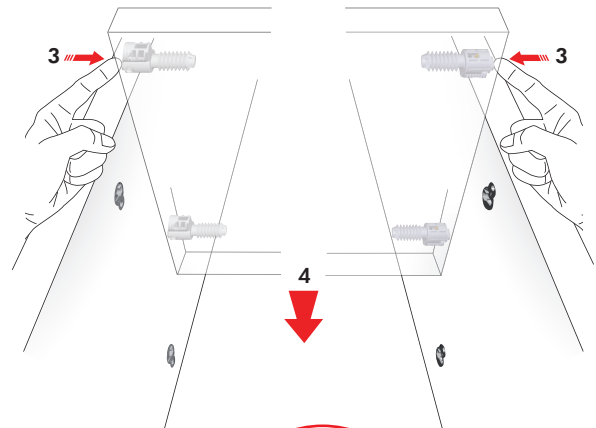
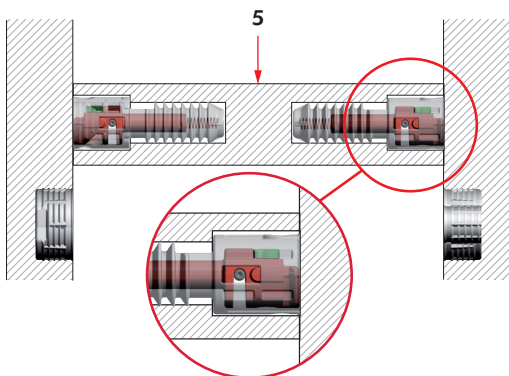
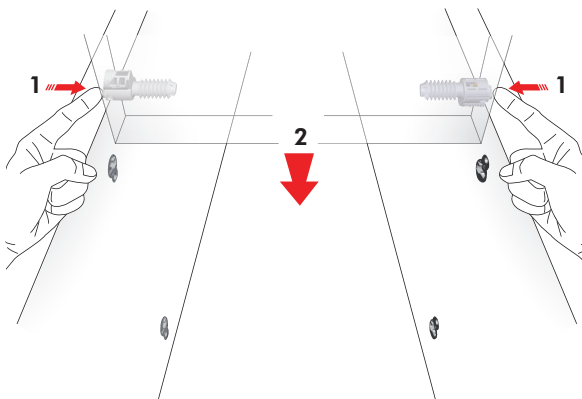



LOCKING DEVICE WHEN SHELVES MOUNTING HINGES FOR LIFT UP OR DROP DOWN DOORS

Ø 4 mm hole allows the access to the minifix with an hexagonal key S 2,5. It can be drilled either on the upper or on the lower side of the shelf, (or even a passing through hole) according to the customer's needs.

SHELF LOCKING

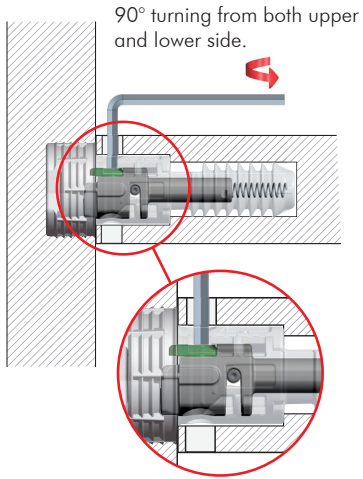

SHELF UNLOCKING

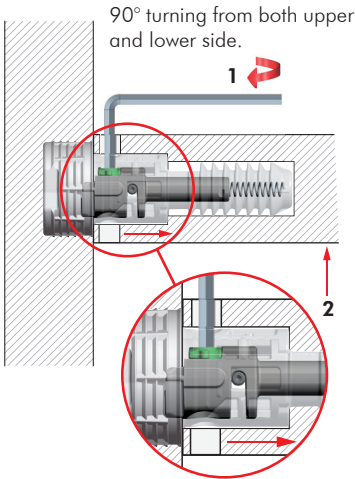

SHELF REMOVAL

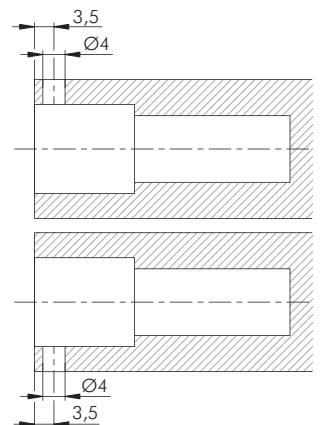
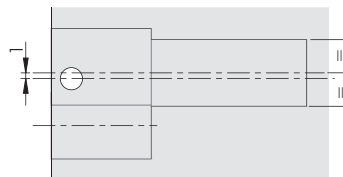
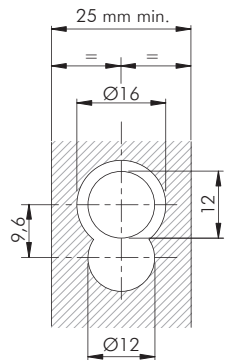
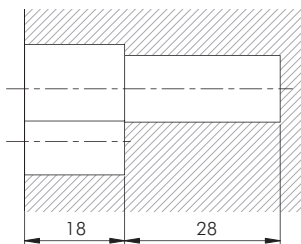
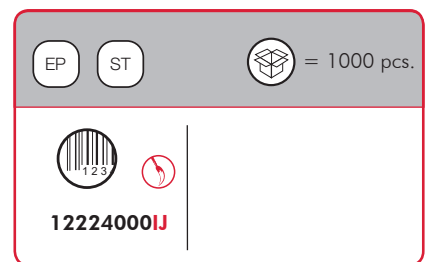
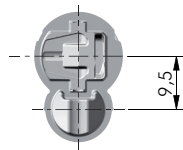
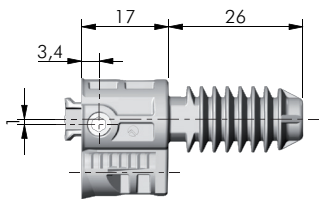
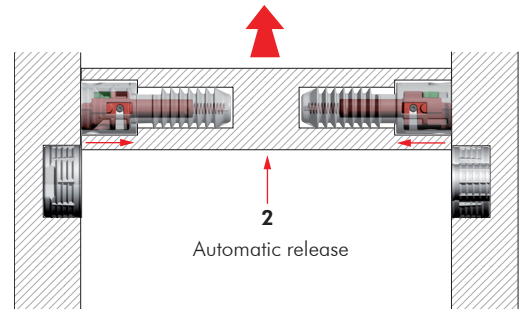
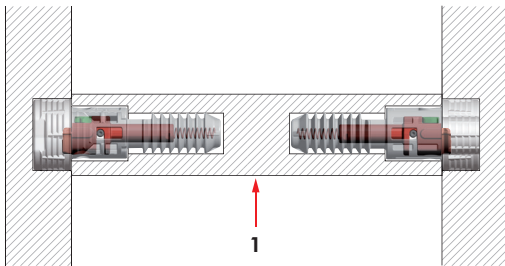

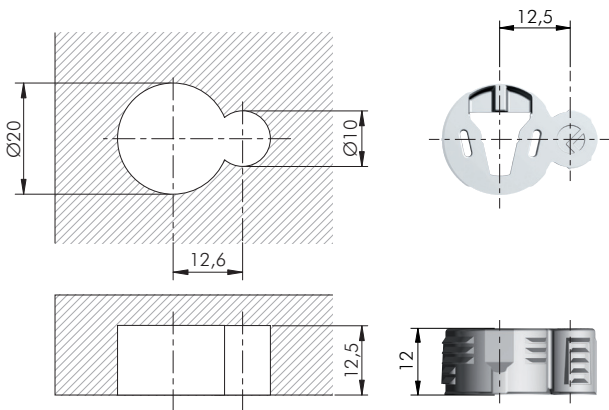

EP	= 5000 pcs.
123	
12226000IJ	

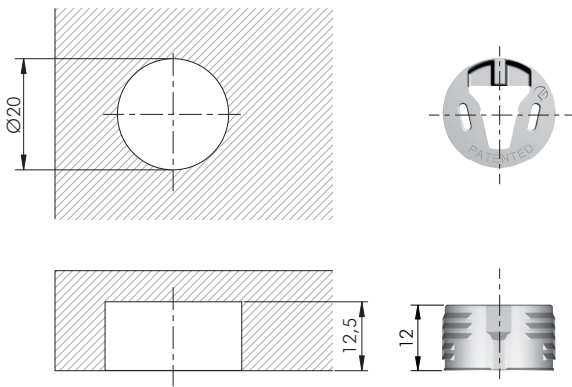

EP	= 1000 pcs.
123	
12228000IJ	

Exclusively conceived for automatic assembly.

SECRET MAXI TEMPLATE FOR SHELF SUPPORT

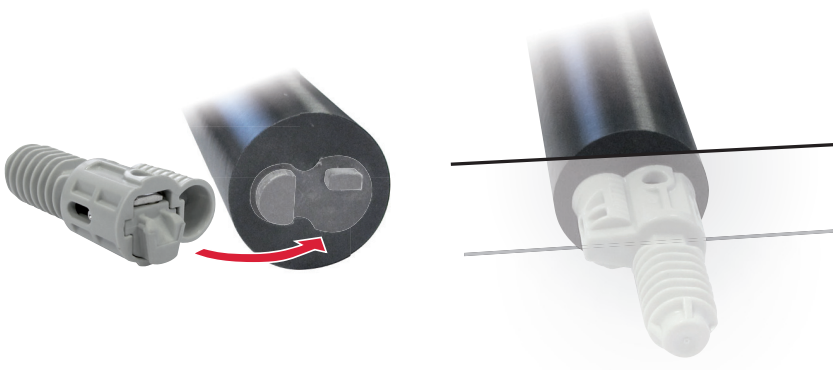

	= on request
123	
1226200000	

SECRET MAXI TEMPLATE FOR SIDE BUSH



	= on request
123	
1226400000	



DRILL BIT FOR SECRET MAXI

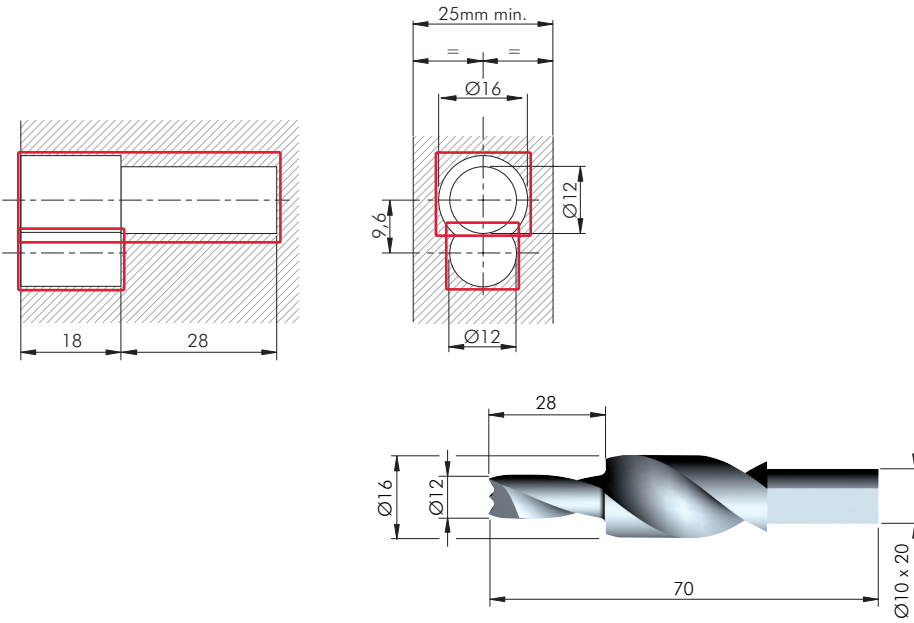

HSS	= on request
123	
1220103000	(R)
1220104000	(L)

DRILL BIT FOR SECRET MAXI SIDE BUSH

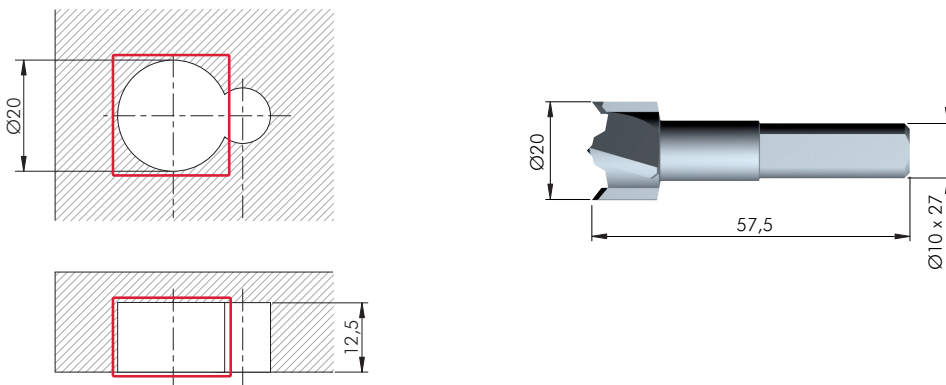

HSS	= on request
123	
1220102000	

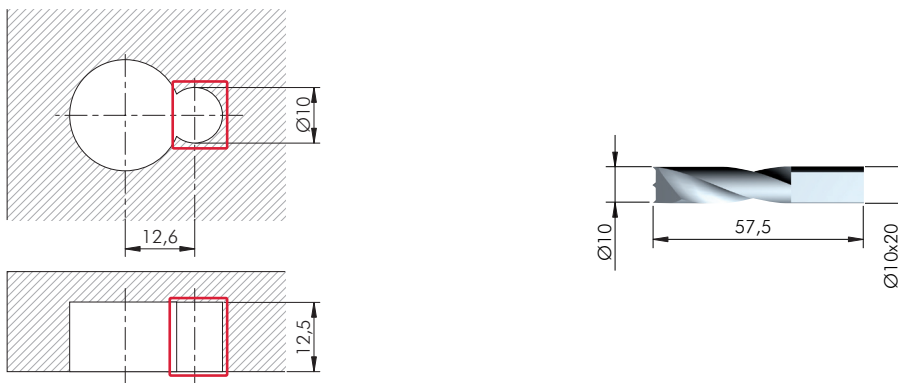

HSS	= on request
123	
1220101000	

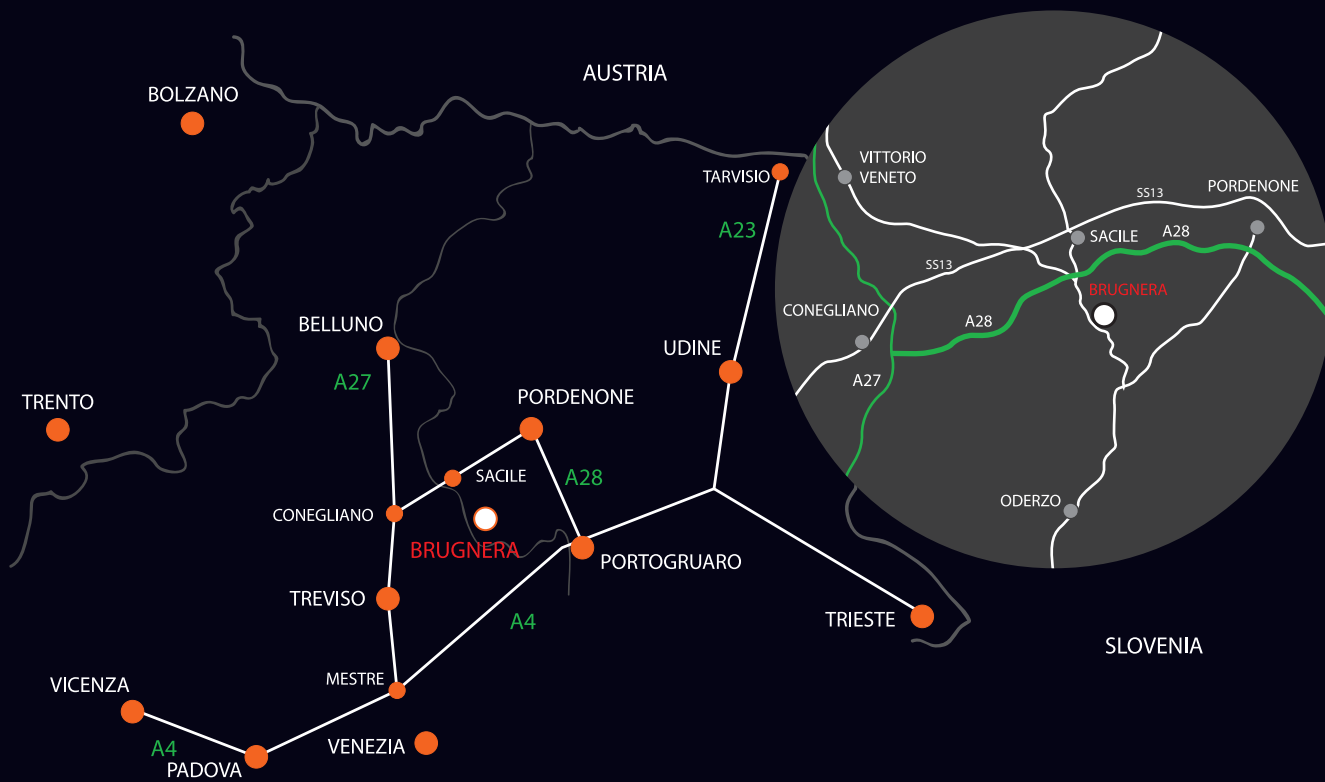

www.italianaferramenta.com