

KINETIC FLATPAX RANGE

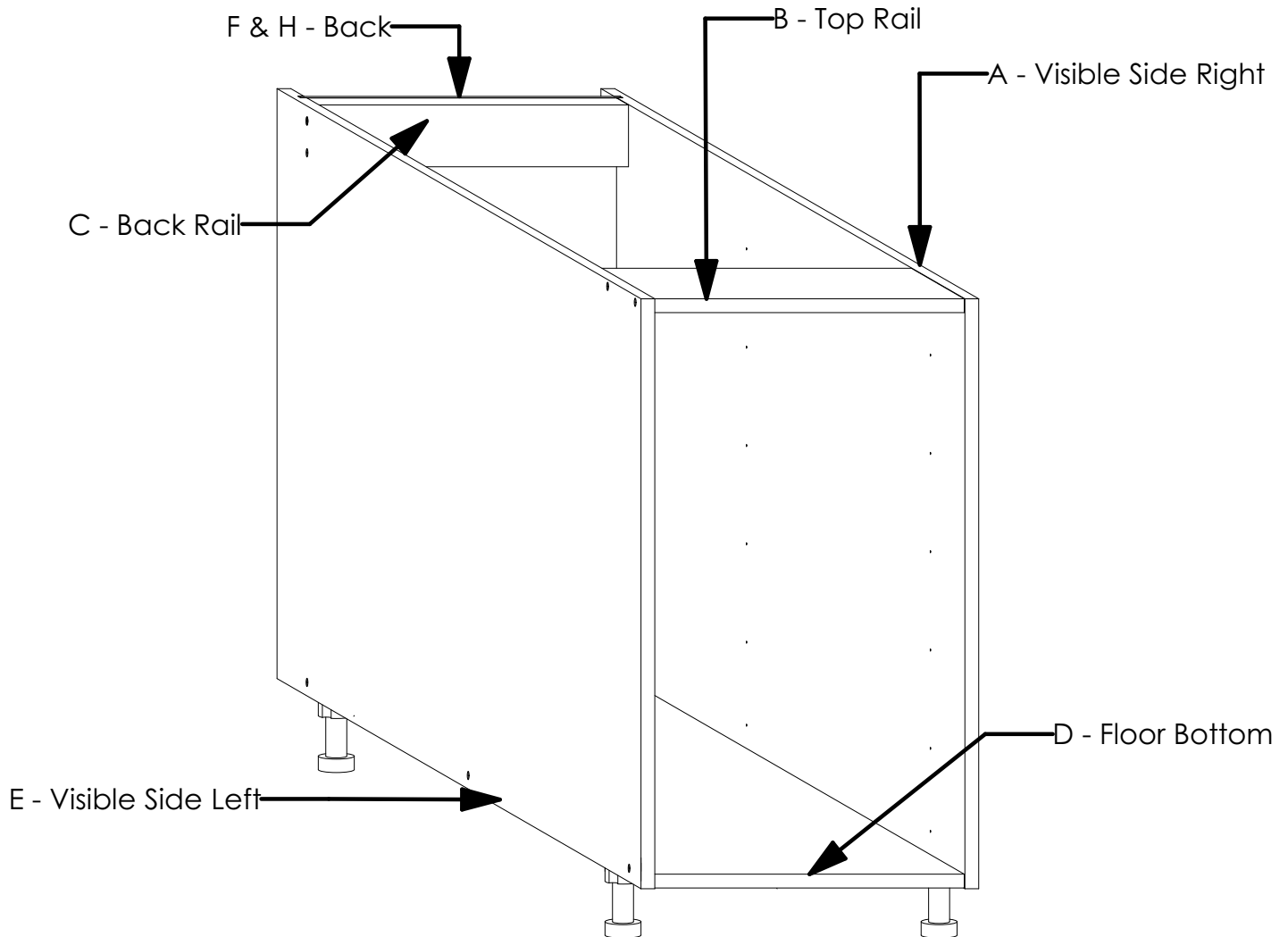



ASSEMBLY GUIDE

BASE CABINET DRAW - 600mm



TOTAL NUMBER OF PANELS: 7

HARDWARE

PRODUCT	QTY	IMAGE
Screw 4.0 x 50mm	14	
Screw 3.5 x 16mm	18	
Plinth Leg With Base H100mm Kit	4	
H Profile Backer Connector	1	

GENERAL INSTRUCTIONS

1. Confirm that all panels (7) are in the package before assembling.
2. Check the white sticker on each panel for the labelling (A, B, C, D, E, F & H).
3. Ensure that the panels are laid on a non-abrasive surface when assembling.
4. Countersink the holes on the side panels before inserting the screws.
5. Ensure that the screw is perpendicular to the surface being drilled for a clean and strong joint.

TOOLS REQUIRED



Screw Driver
(Pozi Head)

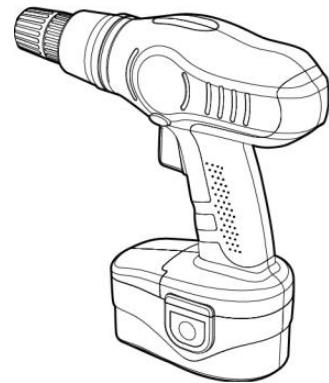

Cordless Drill

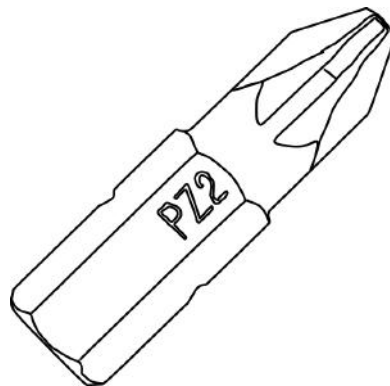

Pozi Bit (PZ2)

STEP 1

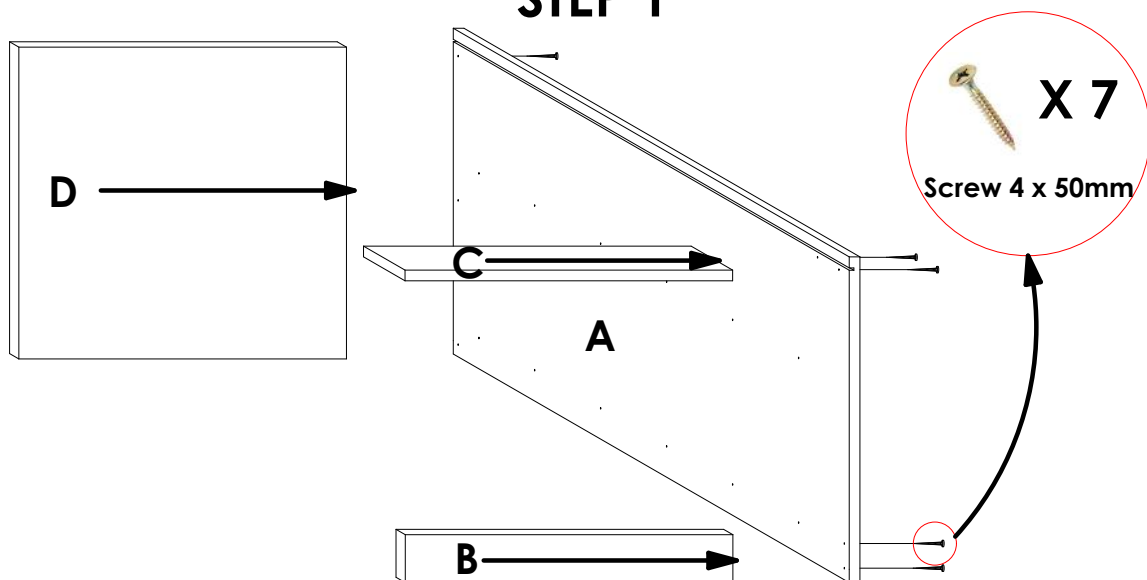

Connect panels **B, C & D** to panel **A** using **Screw 4.0 X 50mm** in the pre-drilled pilot holes as shown. Refer to **Det 1 - 3** below before fastening the screws.

STEP 2

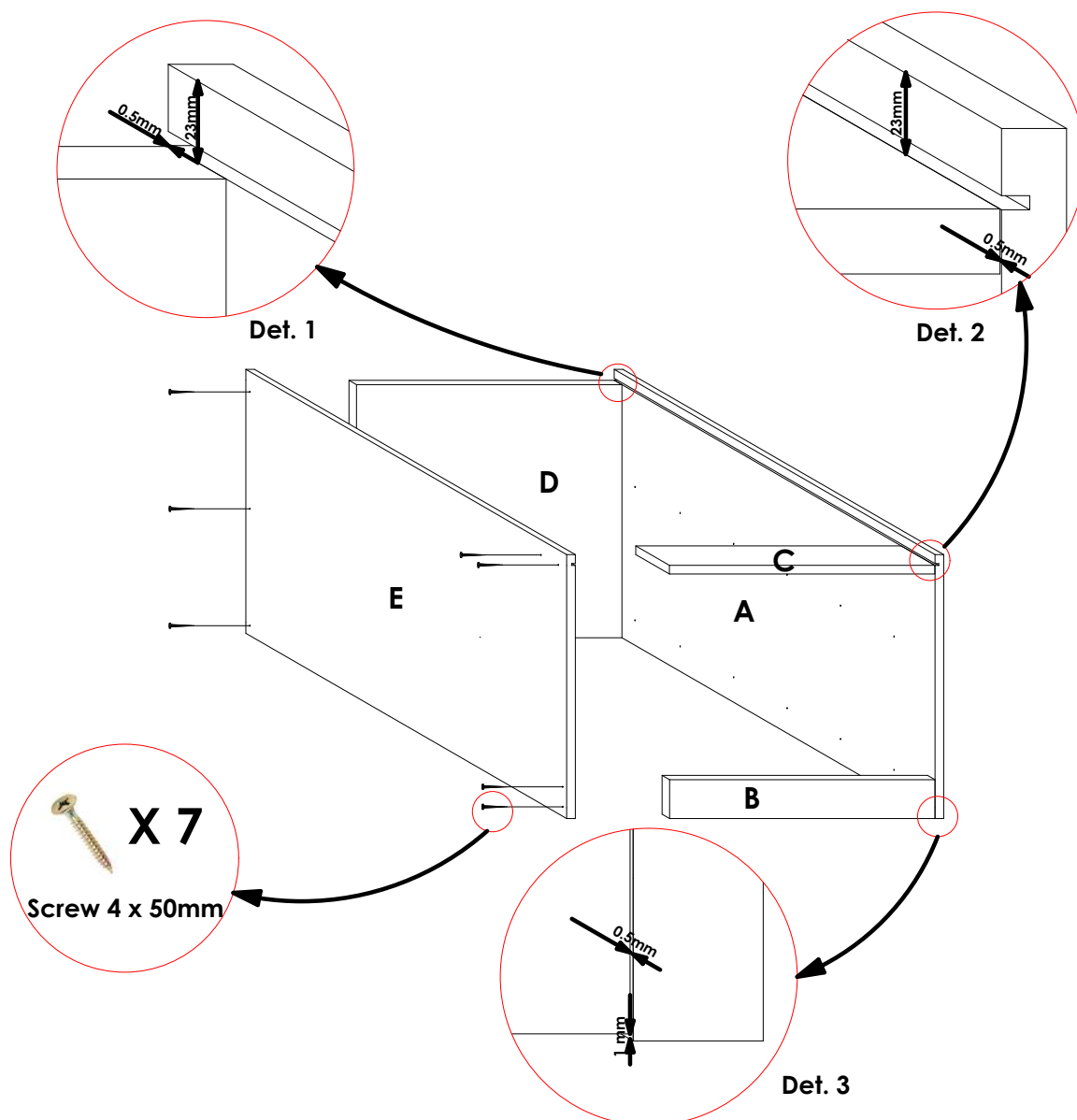

Connect panel **E** to panels **B, C & D** using **Screw 4.0 X 50mm** in the pre-drilled pilot holes as shown. Ensure that the **symmetry** between panel **E** and panel **A** is maintained. Refer to **Det 1 - 3**.

STEP 3

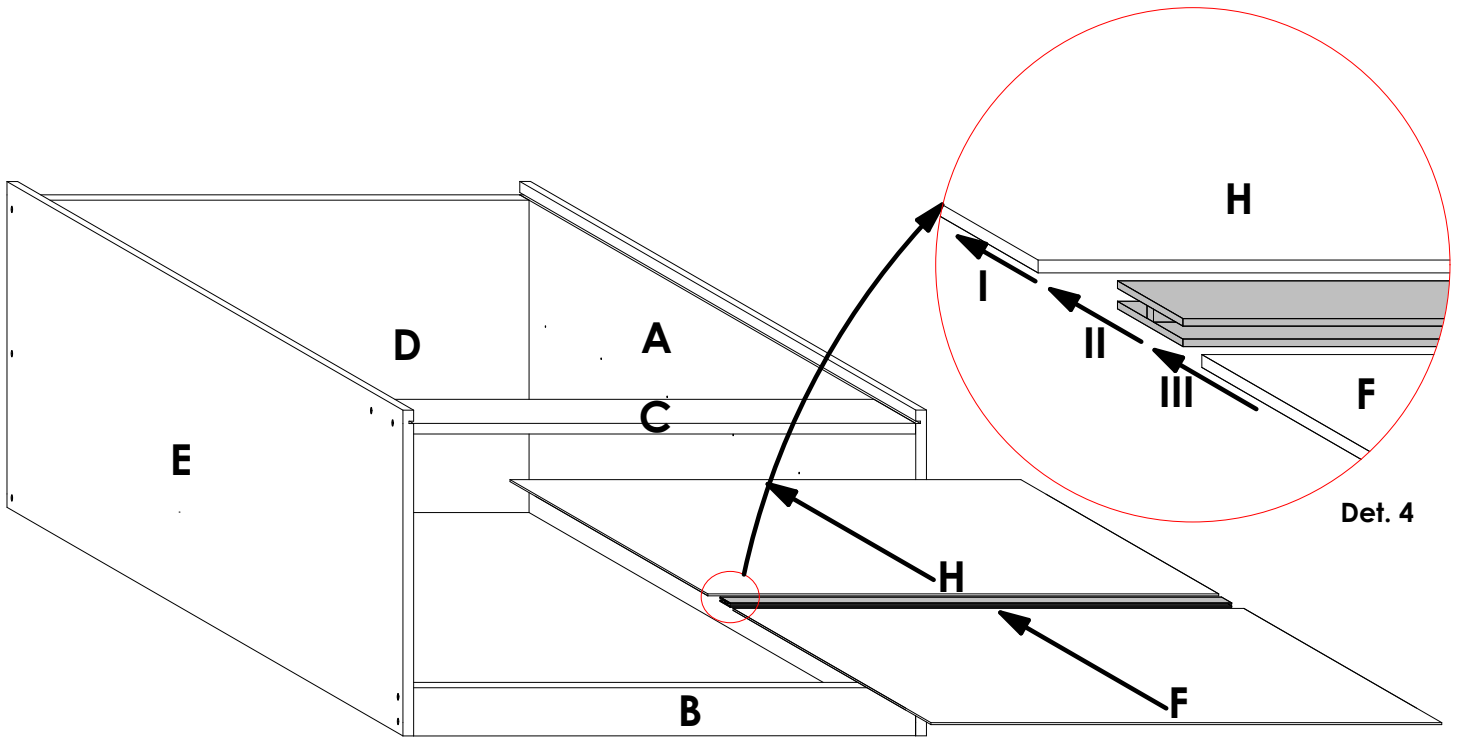

Slide 3mm panel **H** into the groove on panels **A & E** with the finished side facing inside the cabinet. After, insert the **H Profile Backer Connector** into panel **H** as shown (See **Det. 4**). To finish this step, slide 3mm panel **F** into the groove on panels **A & E** and into the **H Profile Backer Connector** as shown in **Det. 4**.

STEP 4

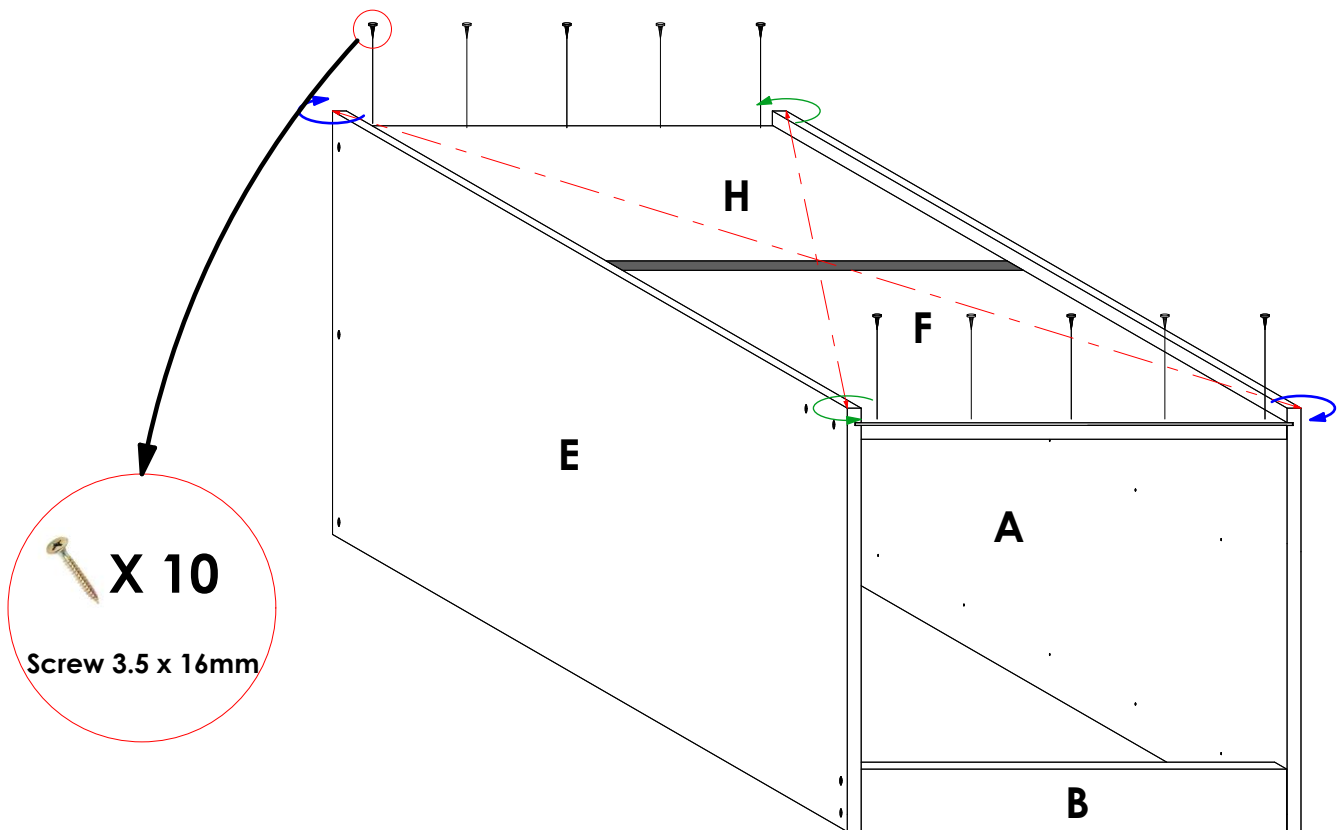

First, **check the diagonal** of the cabinet by measuring the two distances indicated by the red, broken lines. They should be equal. If not, twist the cabinet accordingly in the diagonal corners as shown until an equal value is achieved. After, secure panel **F & H** to panels **C & D** respectively as shown using **Screw 3.5 X 16mm**.

STEP 5

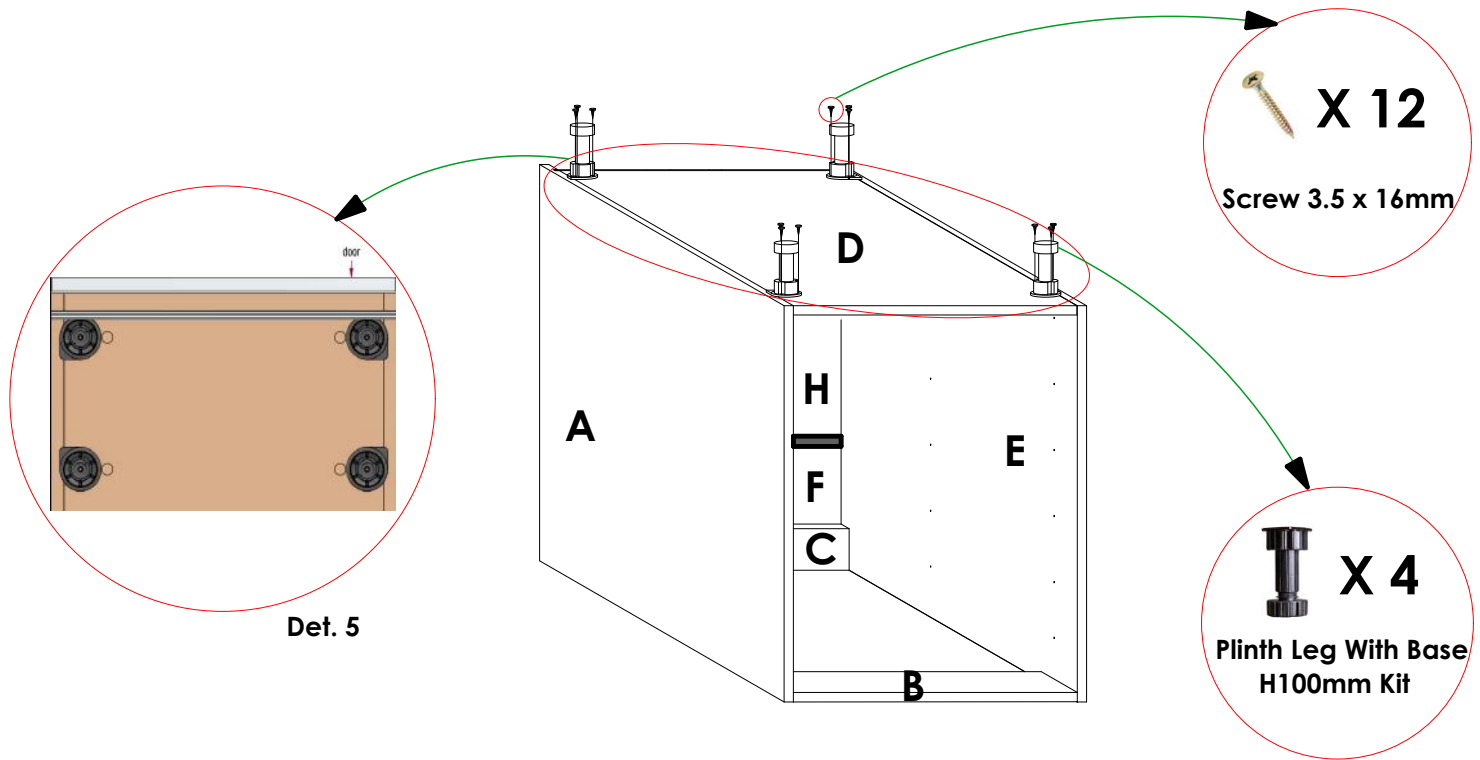

Flip the cabinet up-side down as shown. Place the four units of **Leg Adjustable Base 100mm** in the shown positions, aligning with the pre-drilled pilot holes on panel **D**. Ensure that the orientation is as shown in **Det. 5**. Using **Screw 3.5 X 16mm**, secure the legs onto panel **D**.

STEP 6 (T6)

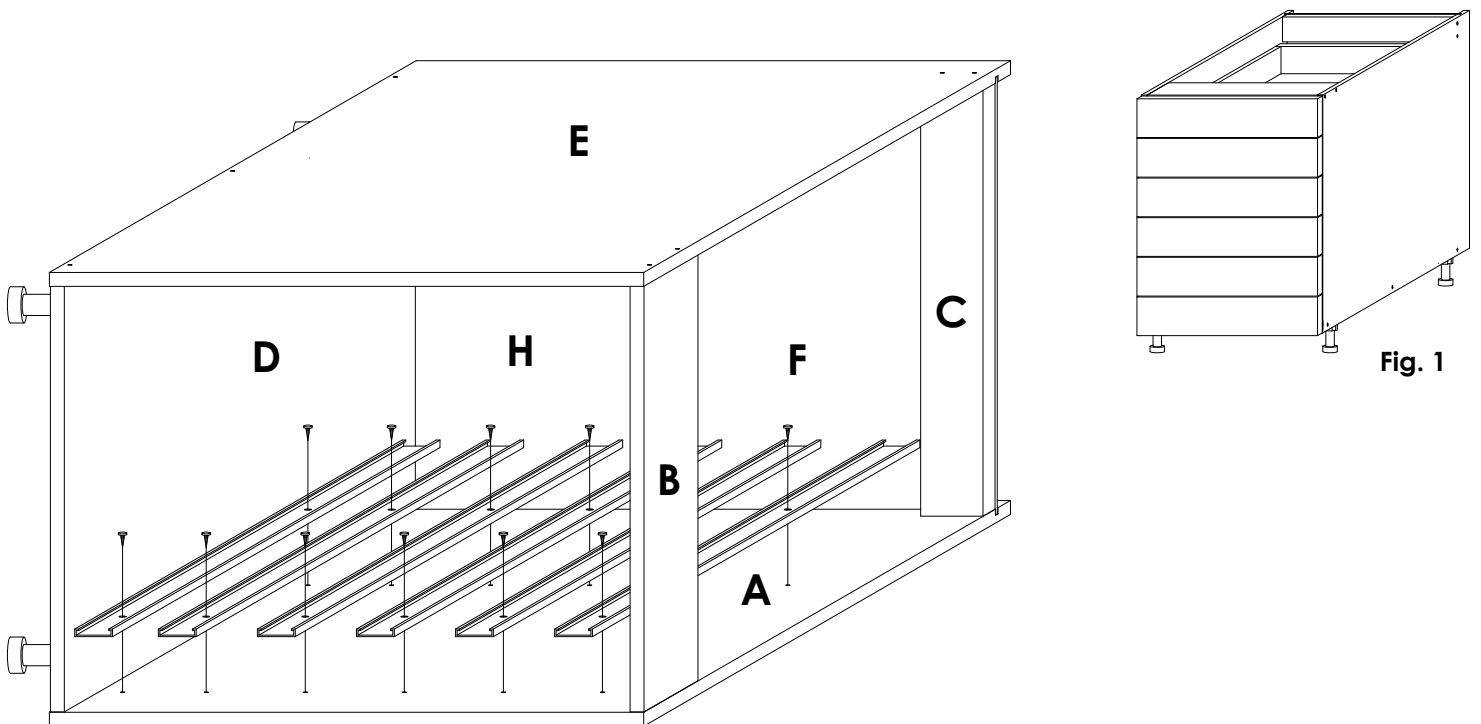

Connect the rails on panel **A** as shown using **Screw 3.5mm x 16mm** in the predrilled pilot holes. Do the same, in similar positions, on panel **E**. **Only Height 1 Drawer boxes (6)** go into this cabinet.

STEP 6 (T123)

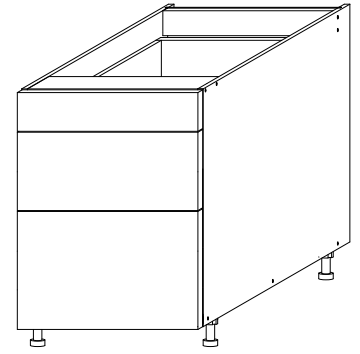
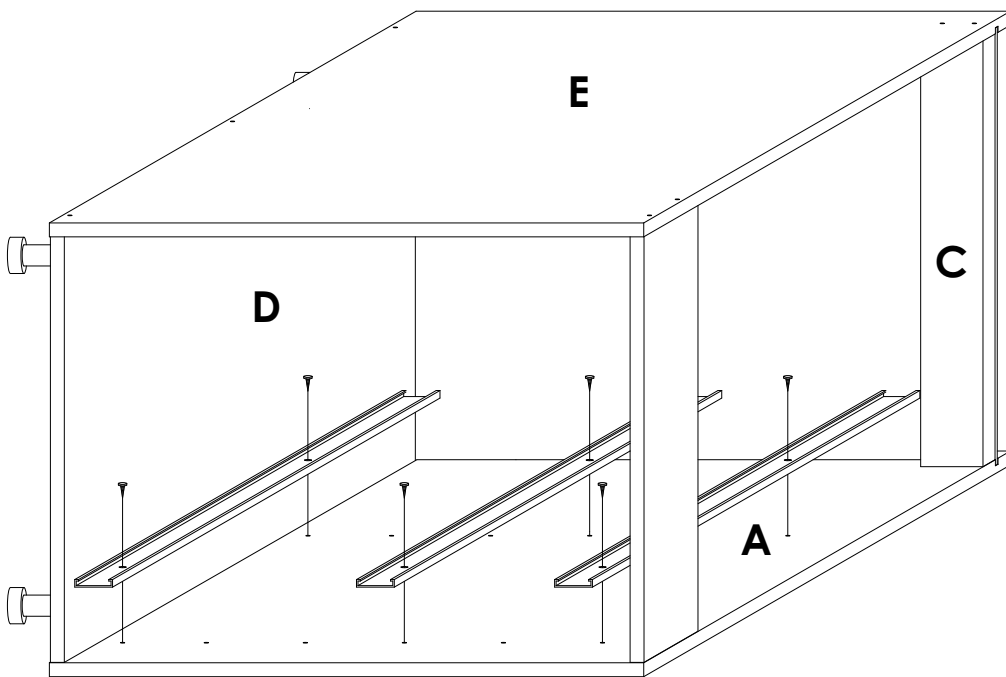

Fig. 2

Connect the rails on panel **A** as shown using **Screw 3.5mm x 16mm** in the predrilled pilot holes. Do the same, in similar positions, on panel **E**. This cabinet carries a **Height 1**, **Height 2** and **Height 3** drawer box; one of each.

STEP 6 (T15)

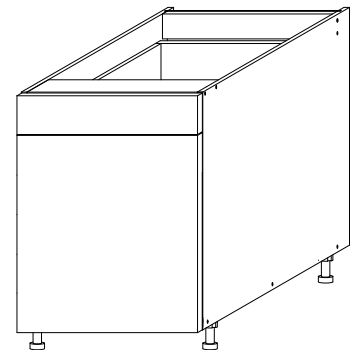
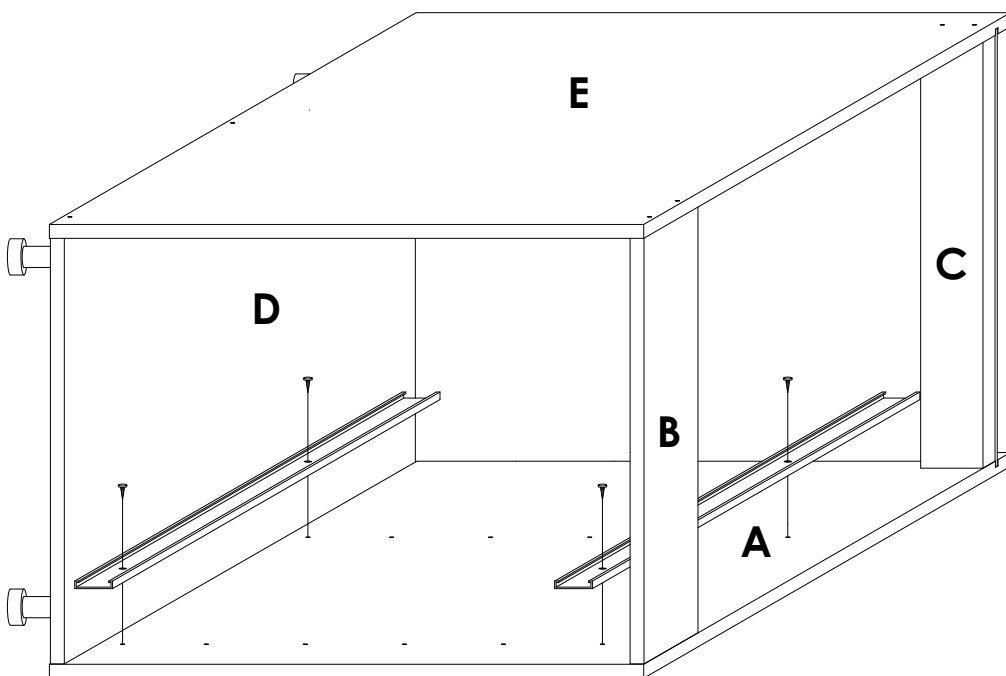

Fig. 3

Connect the rails on panel **A** as shown using **Screw 3.5mm x 16mm** in the predrilled pilot holes. Do the same, in similar positions, on panel **E**. One **Height 1** and one **Height 3** Drawer box go into this cabinet.

STEP 6 (T222)

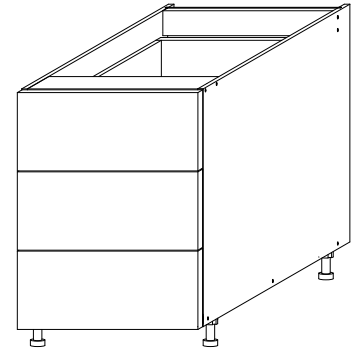
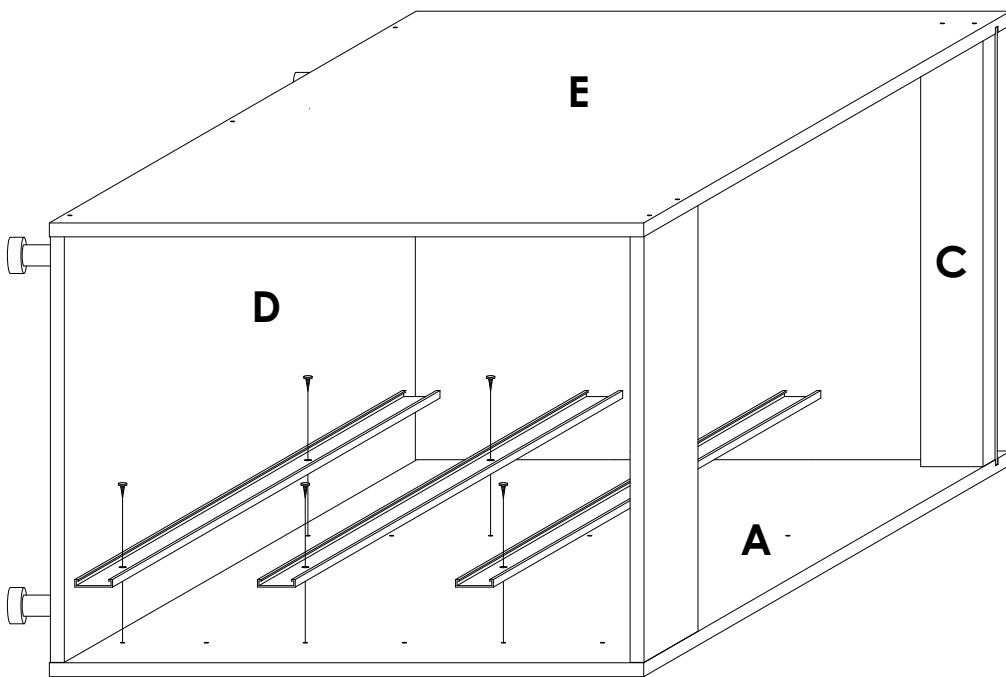

Fig. 4

Connect the rails on panel **A** as shown using **Screw 3.5mm x 16mm** in the predrilled pilot holes. Do the same, in similar positions, on panel **E**. **Only Height 2 Drawer boxes (3)** go into this cabinet.

STEP 6 (T24)

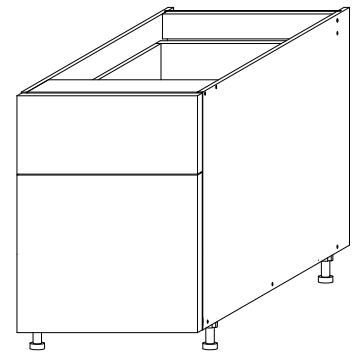
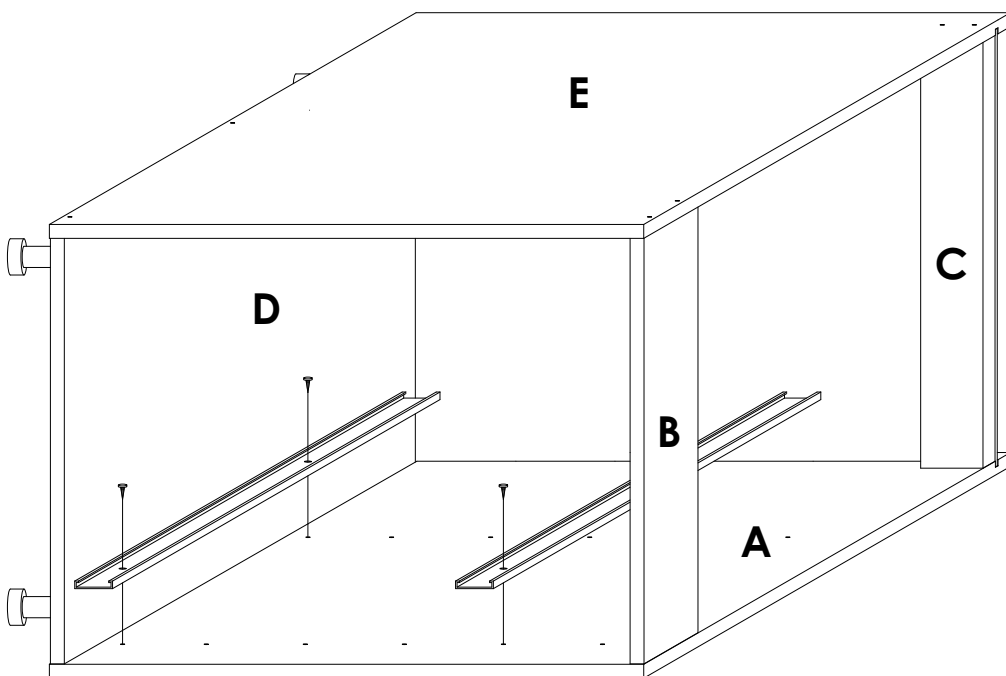
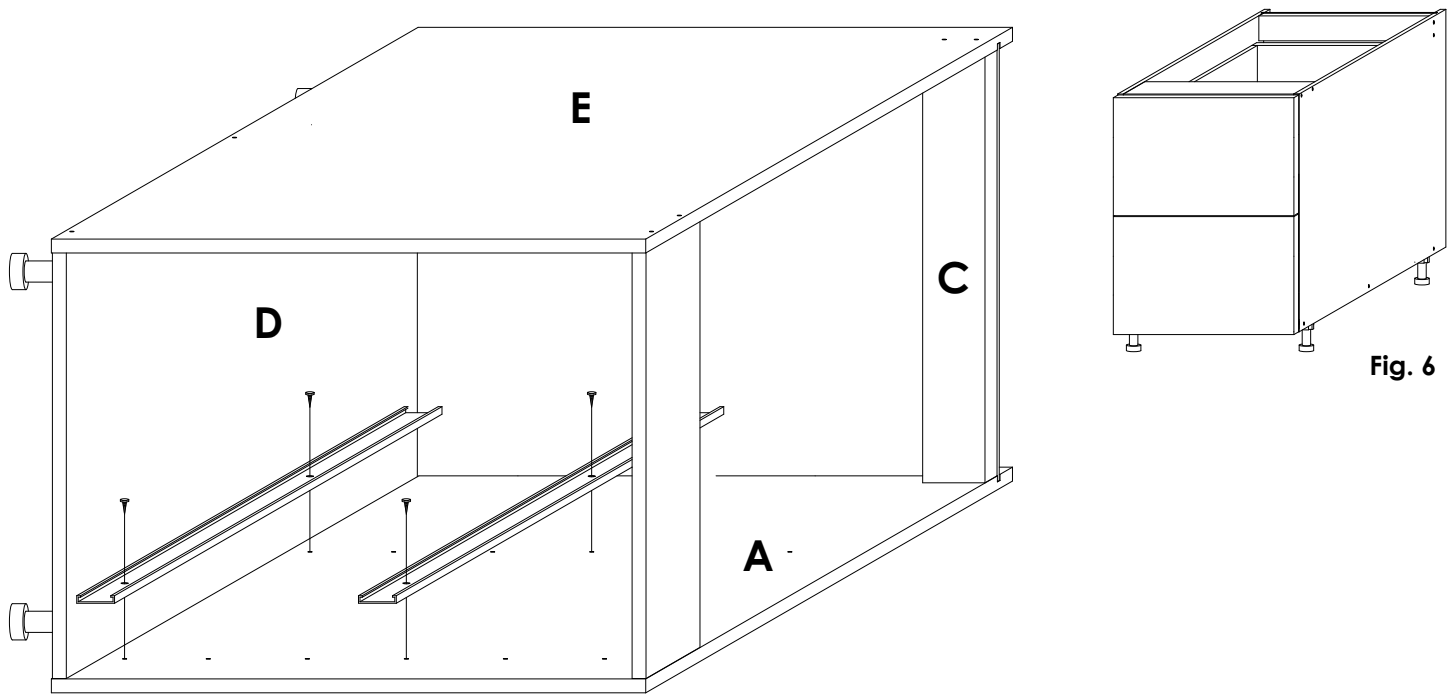

Fig. 5

Connect the rails on panel **A** as shown using **Screw 3.5mm x 16mm** in the predrilled pilot holes. Do the same, in similar positions, on panel **E**. **One Height 2 and one Height 3** Drawer boxes go into this cabinet.

STEP 6 (T33)



Connect the rails on panel **A** as shown using **Screw 3.5mm x 16mm** in the predrilled pilot holes. Do the same, in similar positions, on panel **E**. **Only Height 3 Drawer boxes (2)** go into this cabinet.

STEP 7

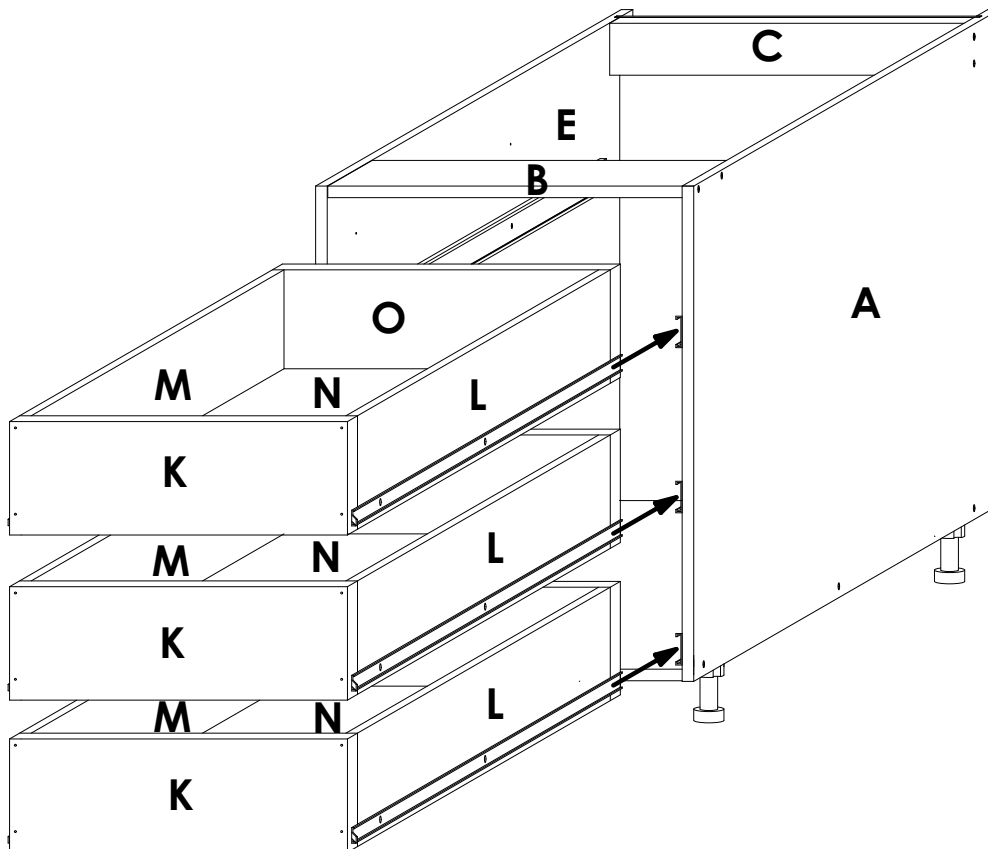

Insert the **runners** on panels **L & M** of the **Drawer box** into the **rails** on panels **A & E** of the **Base Cabinet Draw** as shown. Push the drawer box in until the face of panel **K** is flush with the front edges of panels **A & E**. This applies for the different Drawer configurations.

STEP 8

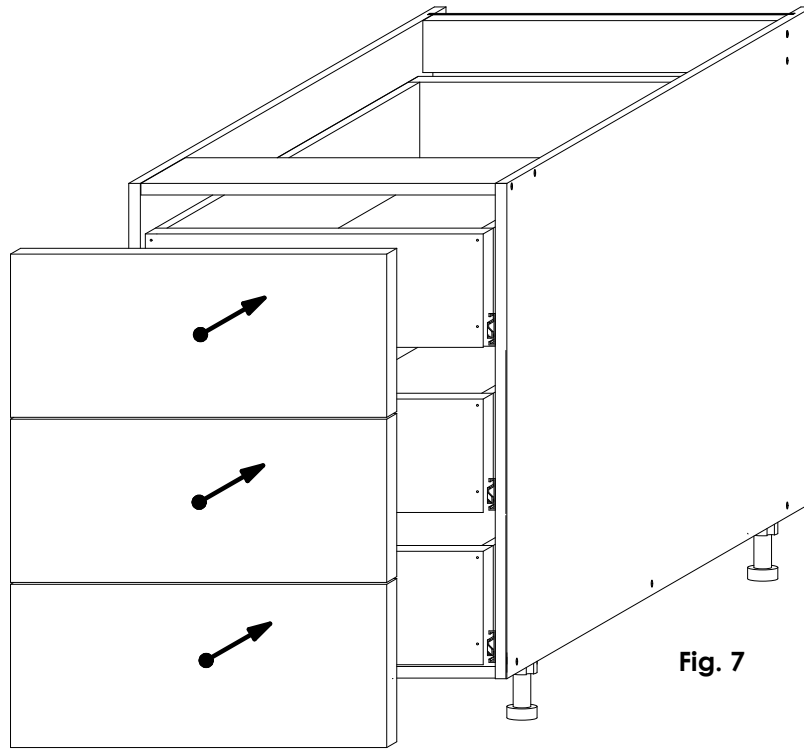
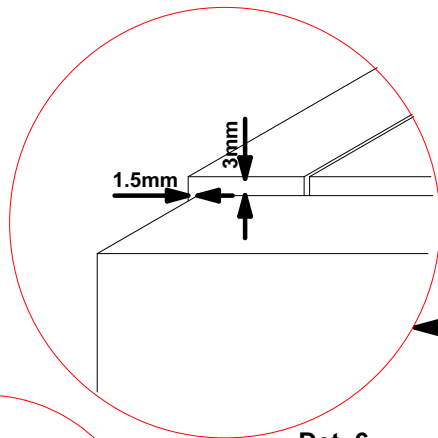
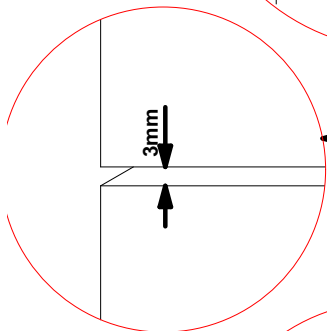

Fig. 7



Det. 6



Det. 7

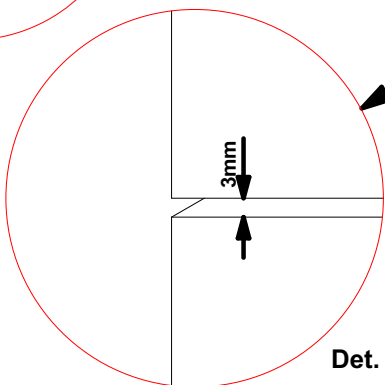

Det. 8

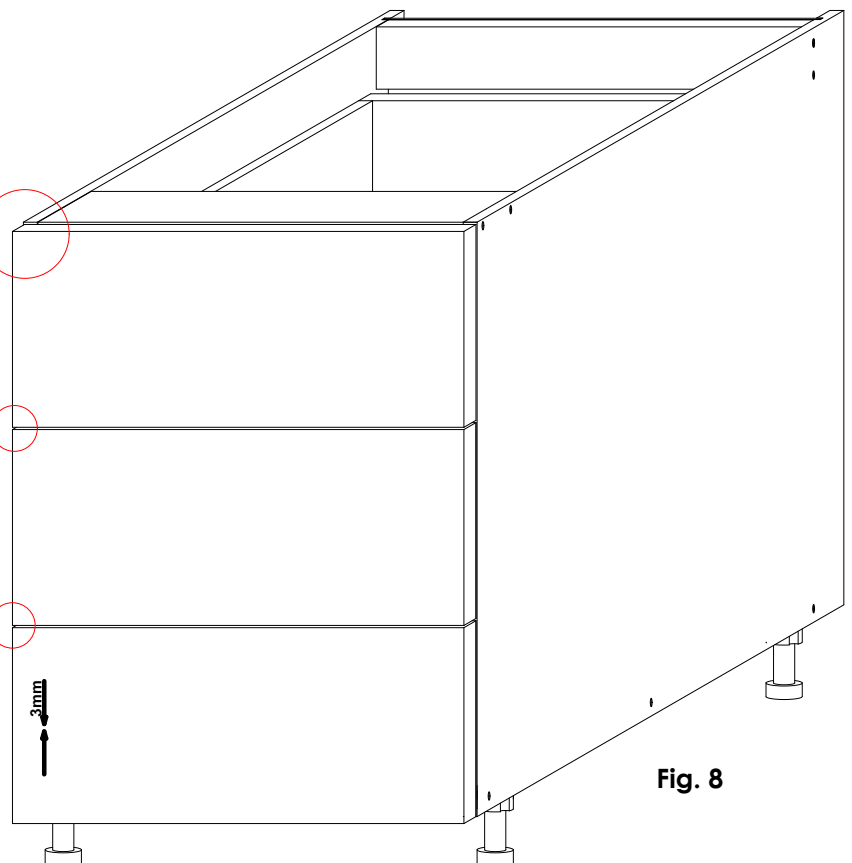

Fig. 8

First, confirm that the **sizes of the drawer fronts** correspond with the **Drawer Configuration** chosen for your **Base Cabinet Draw**. Then, connect the **drawer fronts** to panel **K** using **Screw 4.0 x 30mm** as shown in **Fig. 7**. Refer to **Det. 6 - 8** for the correct clearances. The vertical space between drawer fronts should be **3mm**. There should be a **1.5mm** space between the **left & right edges of the drawer fronts** and the **outer faces of panels A & E**. This applies for all the drawer configurations available. **Fig. 8** shows a **T222** drawer configuration.