

KINETIC FLATPAX RANGE ASSEMBLY GUIDE BASE CABINET OVEN 600mm

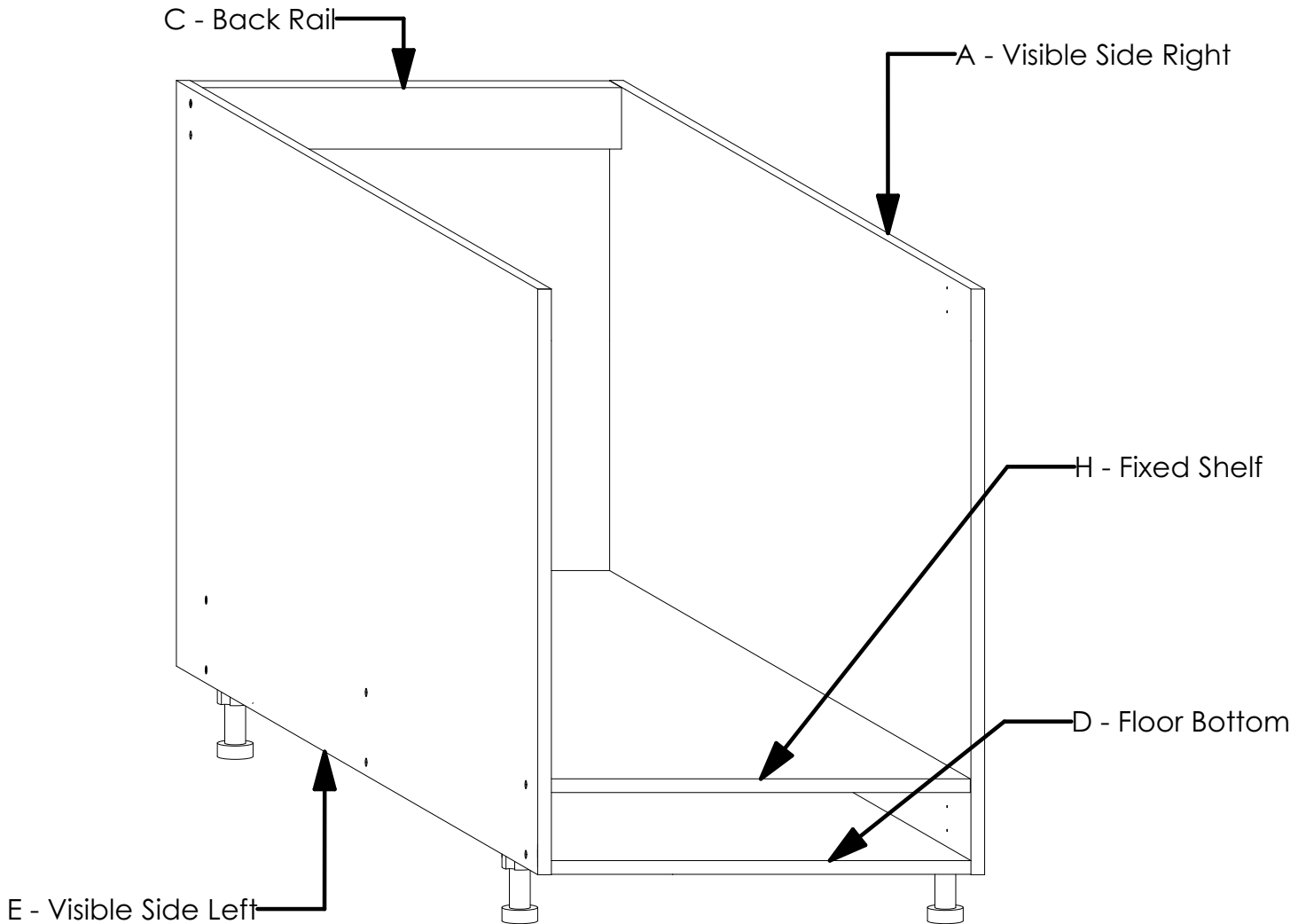

TOTAL NUMBER OF PANELS: 5

HARDWARE

PRODUCT	QTY	IMAGE
Screw 4.0 x 50mm	16	
Screw 3.5 x 16mm	12	
Plinth Leg With Base H100mm Kit	4	

GENERAL INSTRUCTIONS

1. Confirm that all panels (5) are in the package before assembling.
2. Check the white sticker on each panel for the labelling (A, C, D, E & H).
3. Ensure that the panels are laid on a non-abrasive surface when assembling.
4. Countersink the holes on the side panels before inserting the screws.
5. Ensure that the screw is perpendicular to the surface being drilled for a clean and strong joint.

TOOLS REQUIRED



Screw Driver
(Pozi Head)

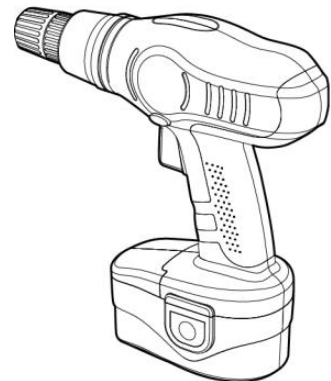

Cordless Drill

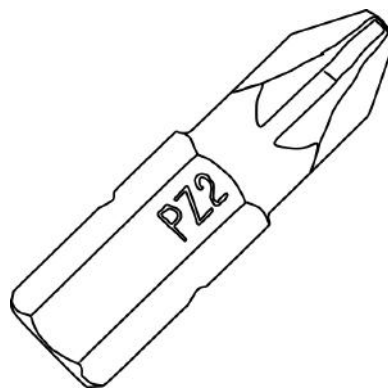

Pozi Bit (PZ2)

STEP 1

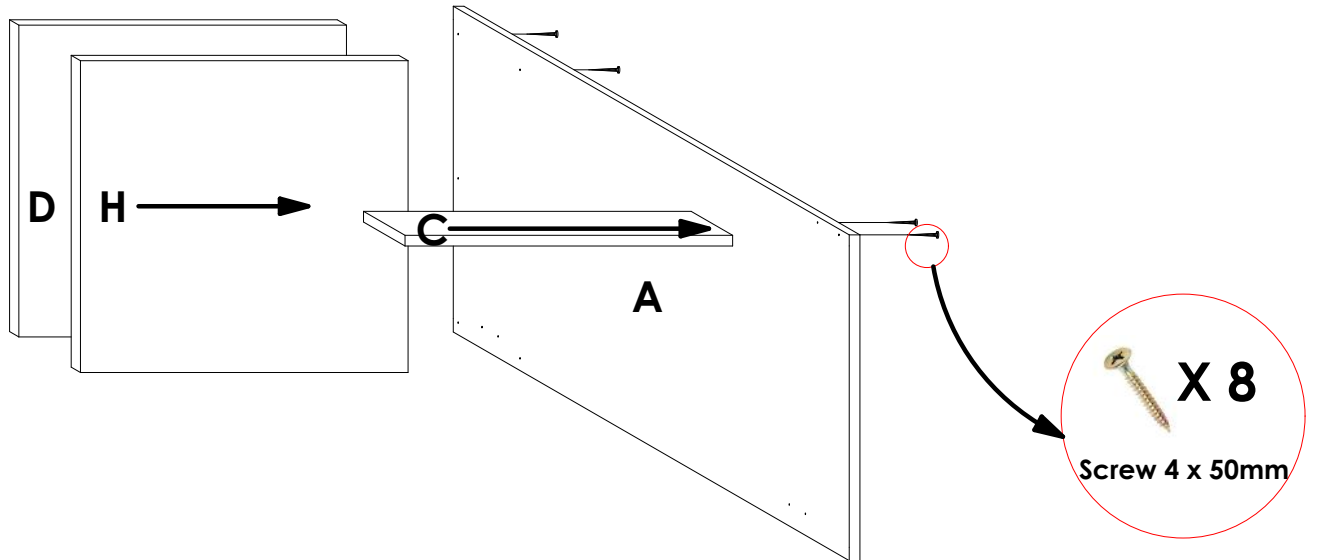

Connect panels **C, D & H** to panel **A** using **Screw 4.0 X 50mm** in the pre-drilled pilot holes as shown. Refer to **Det 1 - 3** below before fastening the screws.

STEP 2

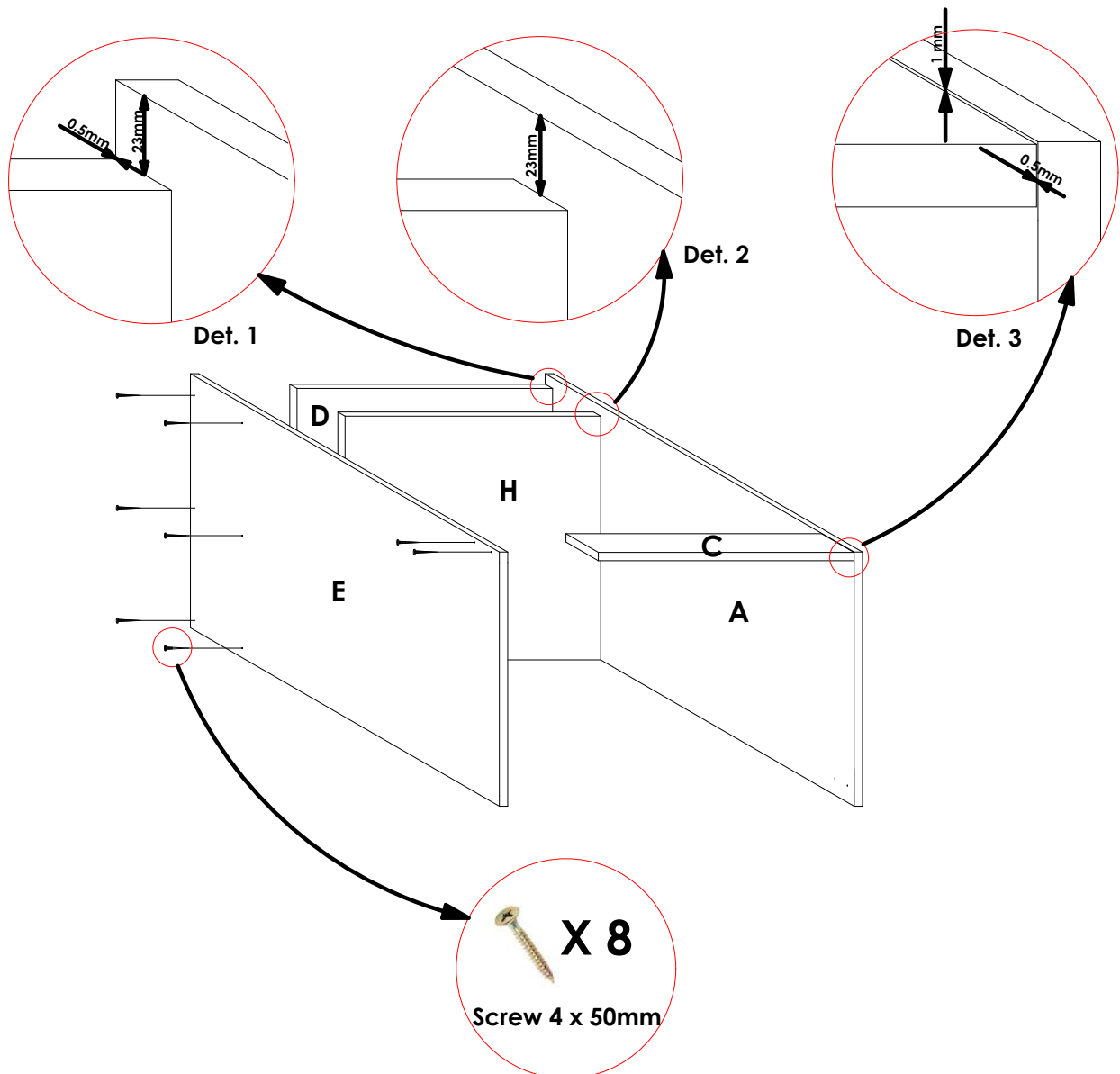

Connect panel **E** to panels **C, D & H** using **Screw 4.0 X 50mm** in the pre-drilled pilot holes as shown. Ensure that the **symmetry** between panel **E** and panel **A** is maintained. Refer to **Det 1 - 3**.

STEP 3

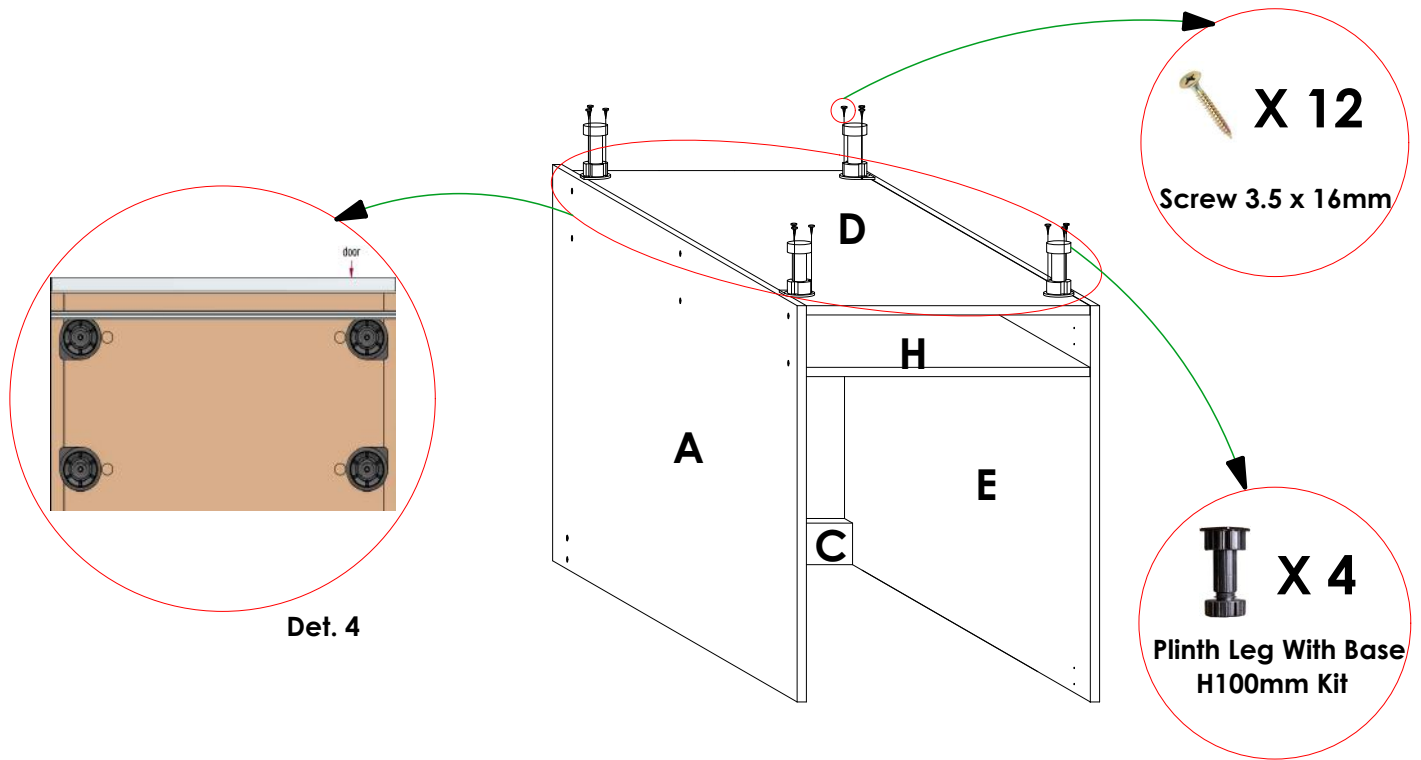

Flip the cabinet up-side down as shown. Place the four units of **Leg Adjustable Base 100mm** in the shown positions, aligning with the pre-drilled pilot holes on panel **D**. Ensure that the orientation is as shown in **Det. 4**. Using **Screw 3.5 X 16mm**, secure the legs onto panel **D**.

STEP 4

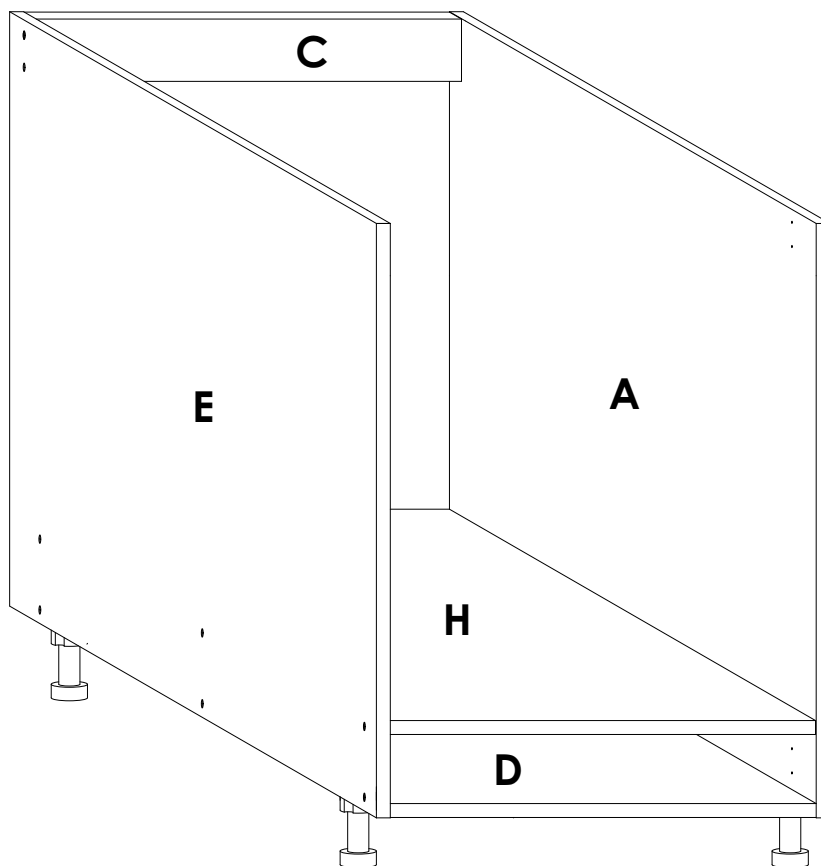

Flip the cabinet upright down as shown and confirm that the legs are secured firmly. Attach the **dummy panels** as per the **Dummy Panels Installation Guide**.