

BLUM FLATPAX KITCHEN RANGE ASSEMBLY GUIDE

TANDEM WOODEN DRAWER BOX HEIGHT 2

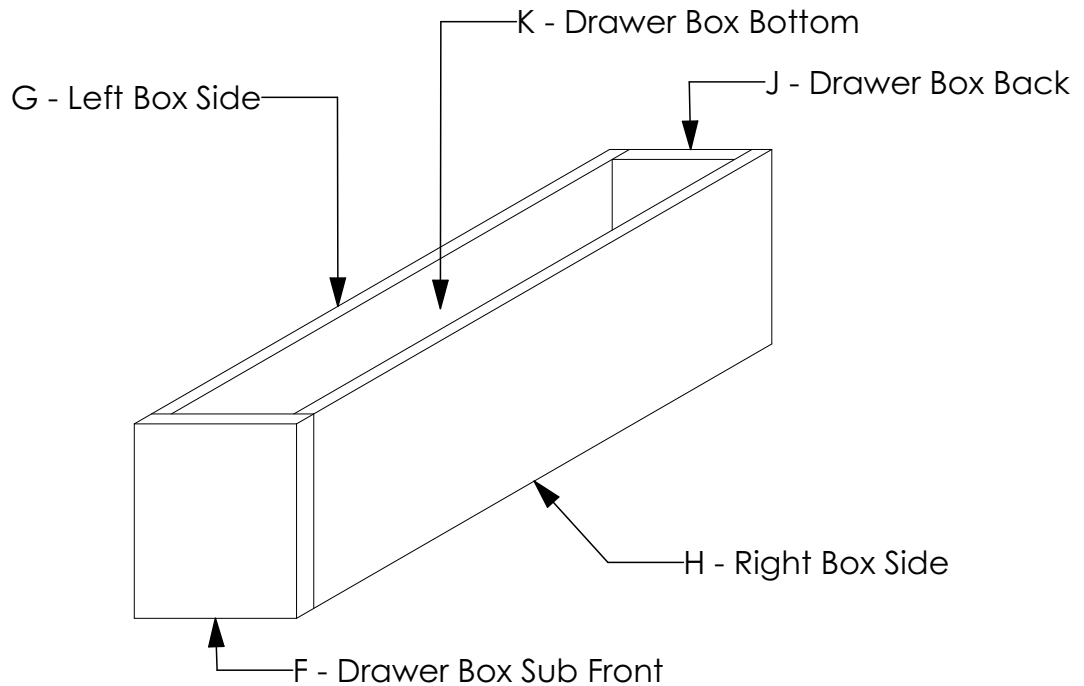

TOTAL NUMBER OF PANELS: 5

HARDWARE

PRODUCT	QTY	IMAGE
Sys5 Quickfit TL2 Dowel 8 x 34	8	
Sys5 Cam 3000 15 x 14 mm	8	
Wooden Dowel	4	
Screw 3.5 x 16mm	12	
Screw 4.0 x 30mm	2	
Tandem Blumotion Single Extension For 18mm 500mm Left&Right	1	
Tandem Locking Device Left & Right	2	
Front Adjustment Bracket Knock In	2	
Dome Screw M4 x 25	2	

TOOLS REQUIRED



Screw Driver
(Pozi Drive Head)



Cordless Drill



Pozi Bit (PZ2)



8mm Drill Bit



Rubber Mallet

GENERAL INSTRUCTIONS

1. Confirm that all panels (5) are in the package before assembling.
2. Check the white sticker on each panel for the labelling (F, G, H, J & K).
3. Ensure that the panels are laid on a non-abrasive surface when assembling.
4. Note that all panel connections are done using the system described below.

PANEL CONNECTION AND FASTENING

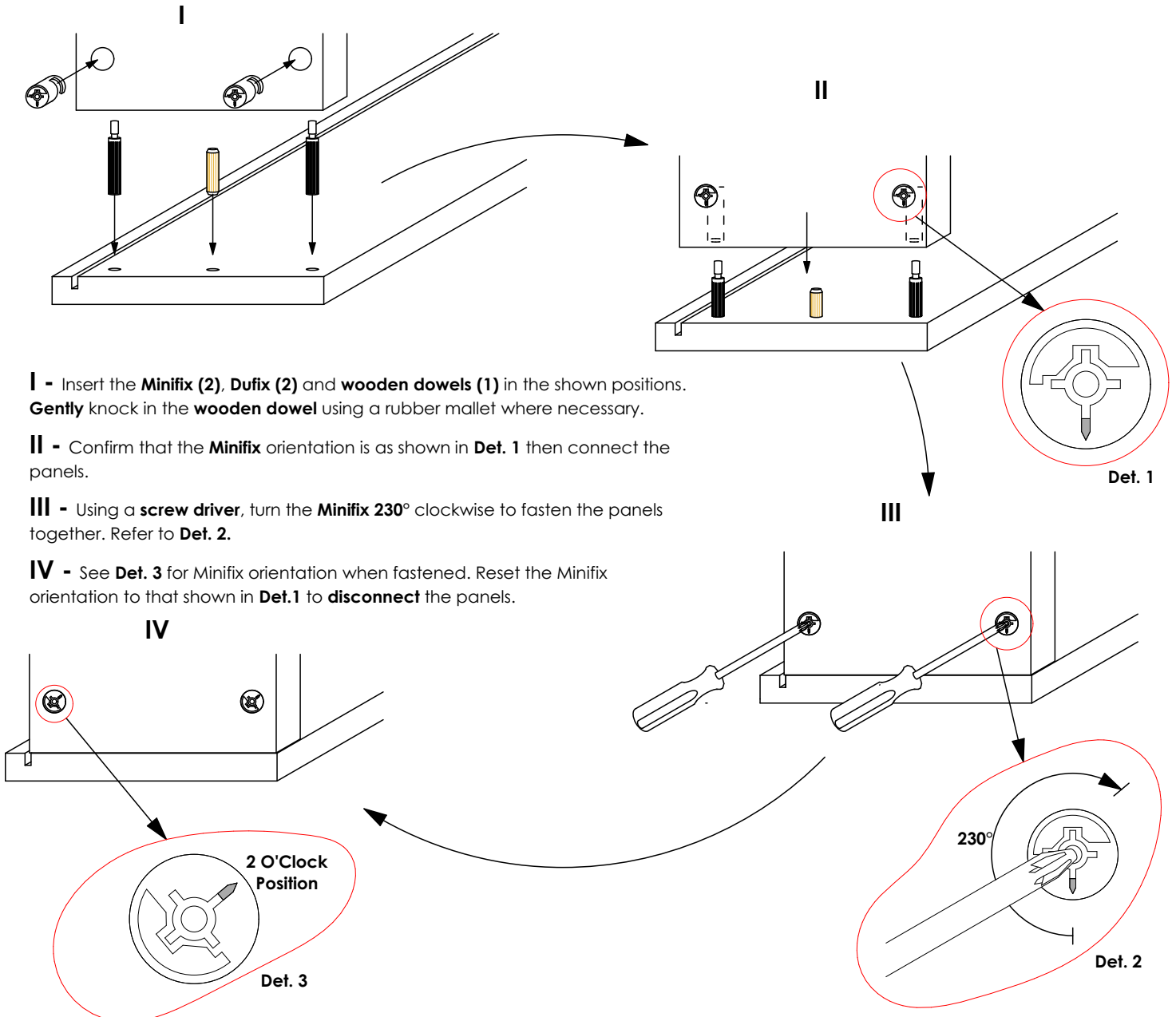

STEP 1

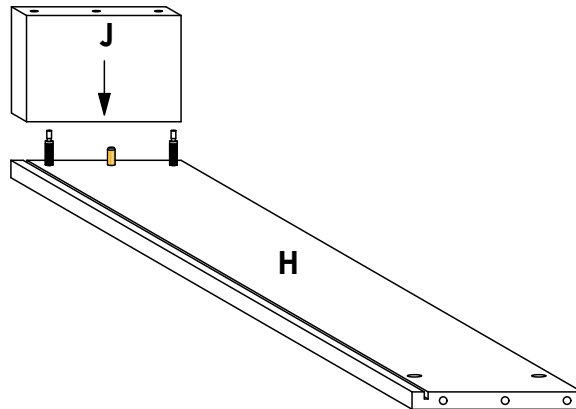

Connect panel **J** to panel **H** as shown. Refer to the holes and/or grooves on the diagram to determine the panel orientation.

STEP 2

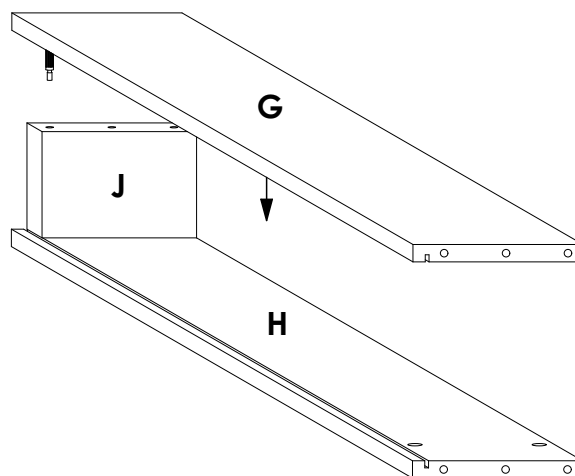

Connect panel **G** to panel **J** as shown. Refer to the holes and/or grooves on the diagram to determine the panel orientation.

STEP 3

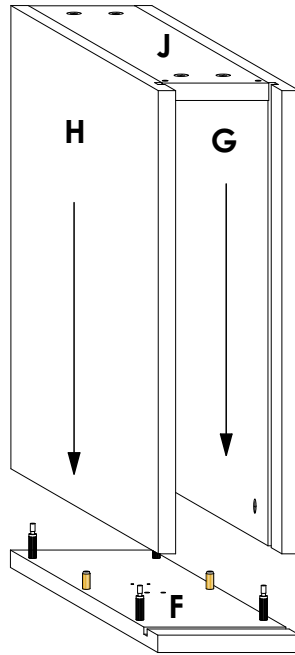

Connect panels **H & G** to panel **F** as shown. Refer to the holes and/or grooves on the diagram to determine the panel orientation.

STEP 4

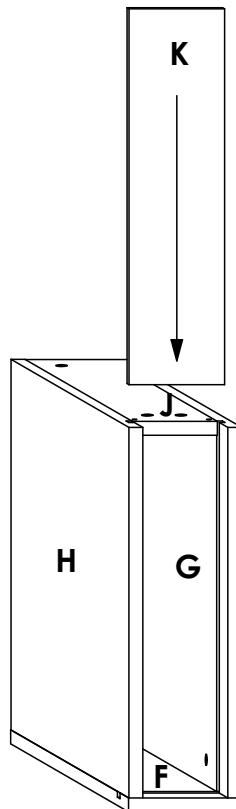

Slide **3mm** panel **K** through the grooves on panels **H & G** and into the groove on panel **F** as shown. Refer to the holes and/or grooves on the diagram to determine the panel orientation.

STEP 5

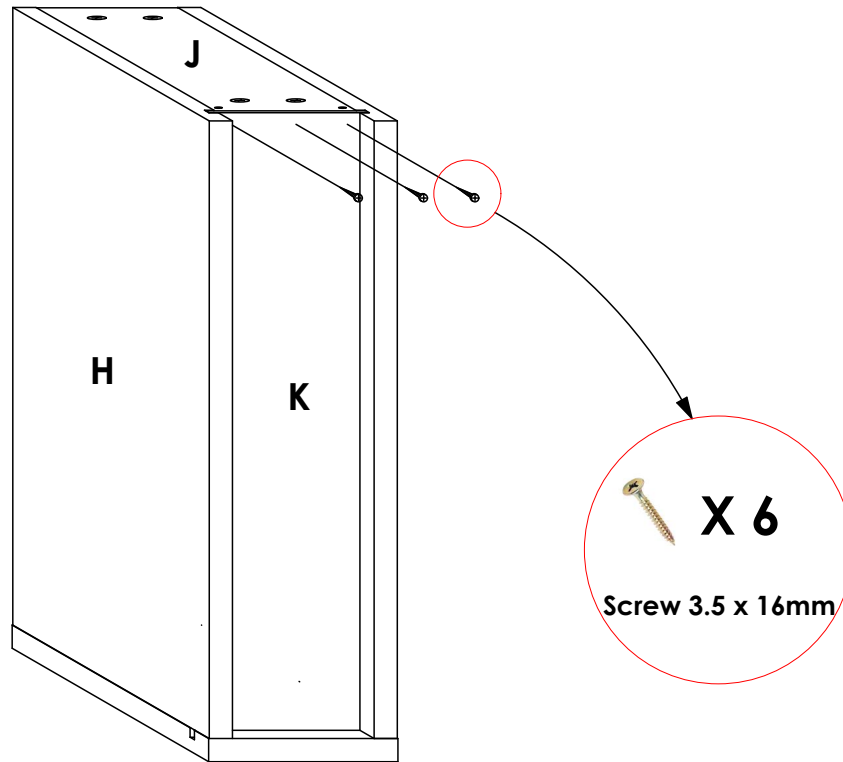

Secure the **3mm** panel **K** onto panel **J** using **Screw 3.5 x 16mm**. Refer to the holes and/or grooves on the diagram to determine the panel orientation.

STEP 6

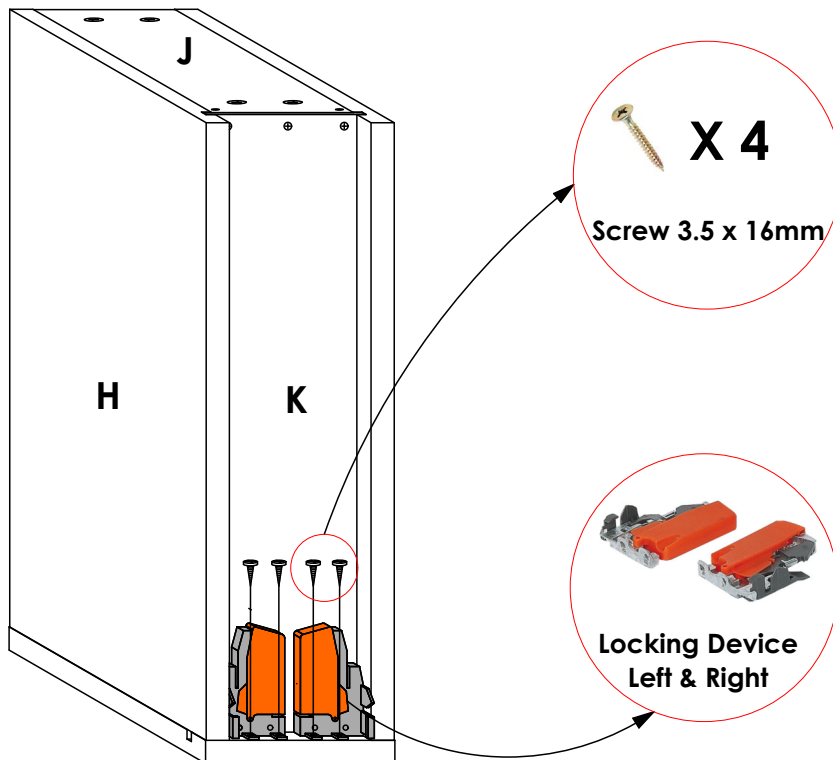

Place the **Tandem Locking Devices** in the shown positions, aligning them with the pre-drilled pilot holes. Secure the **locking devices** onto panel **F** using **Screw 3.5 x 16mm**.

STEP 7

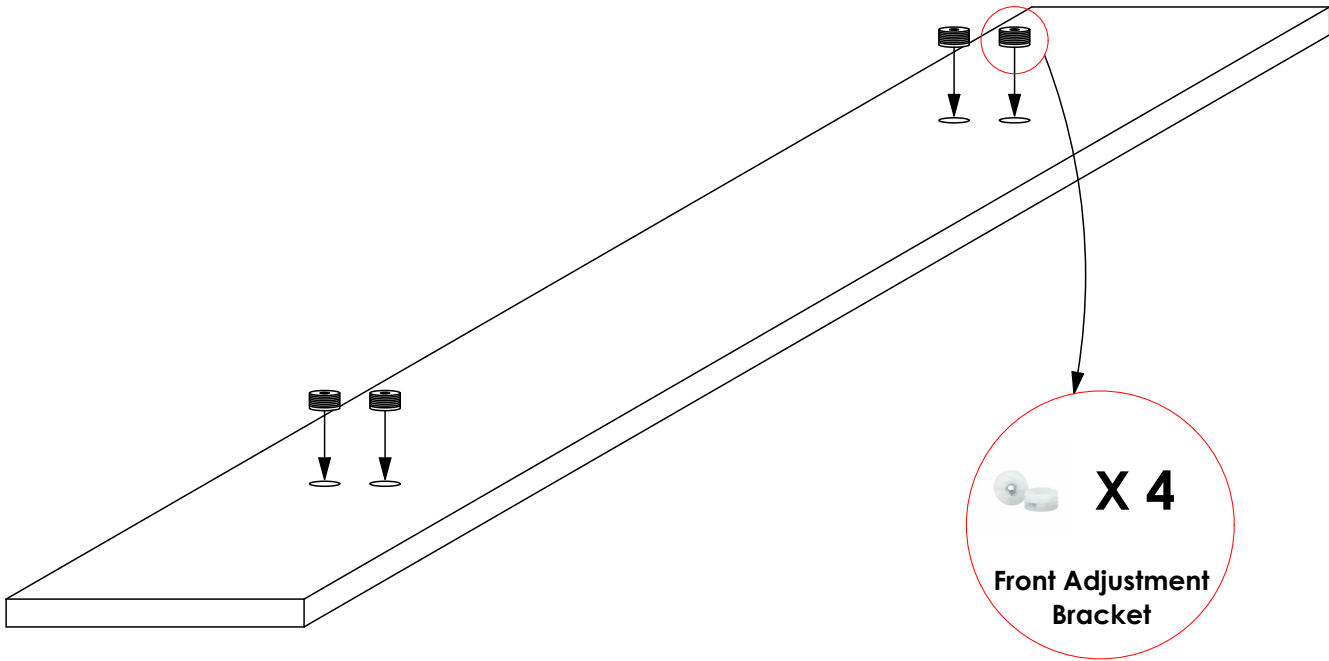

Using a rubber mallet, gently knock in the **Front Adjustment Brackets** into the Drawer Front (Ordered Separately) in the shown positions. Confirm that they go all the way in such that no part appears above the surface of the panel.

STEP 8

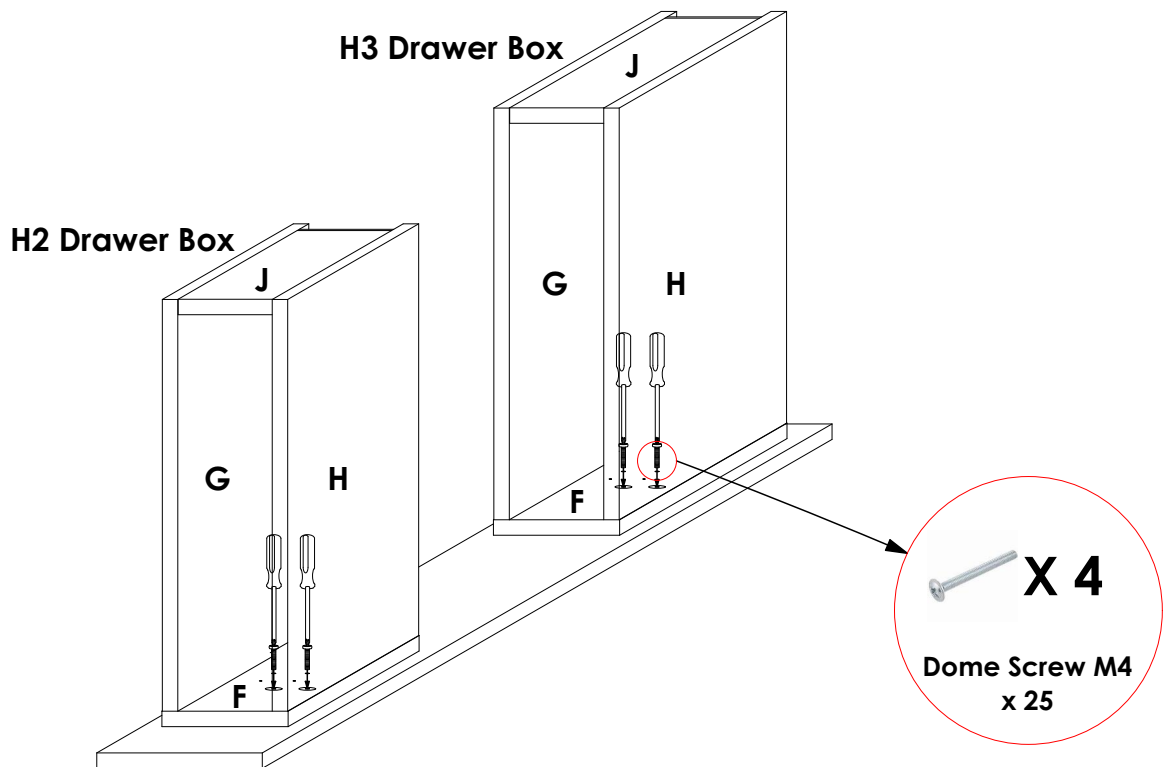

First, using a **5mm Drill Bit**, drill through the **5mm diameter pilot hole** on panel **F**. After, Place the **Height 2** and **Height 3** drawer boxes on the Drawer Front as shown. Connect the Drawer boxes to the Drawer Front using **Dome Screw M4 x 25** through the **5mm through hole** and into the **Front Adjustment Brackets**. Refer to the **Base Cabinet 200mm** Assembly Guide for further instructions