

# BLUM GOLA FLATPAX KITCHEN RANGE

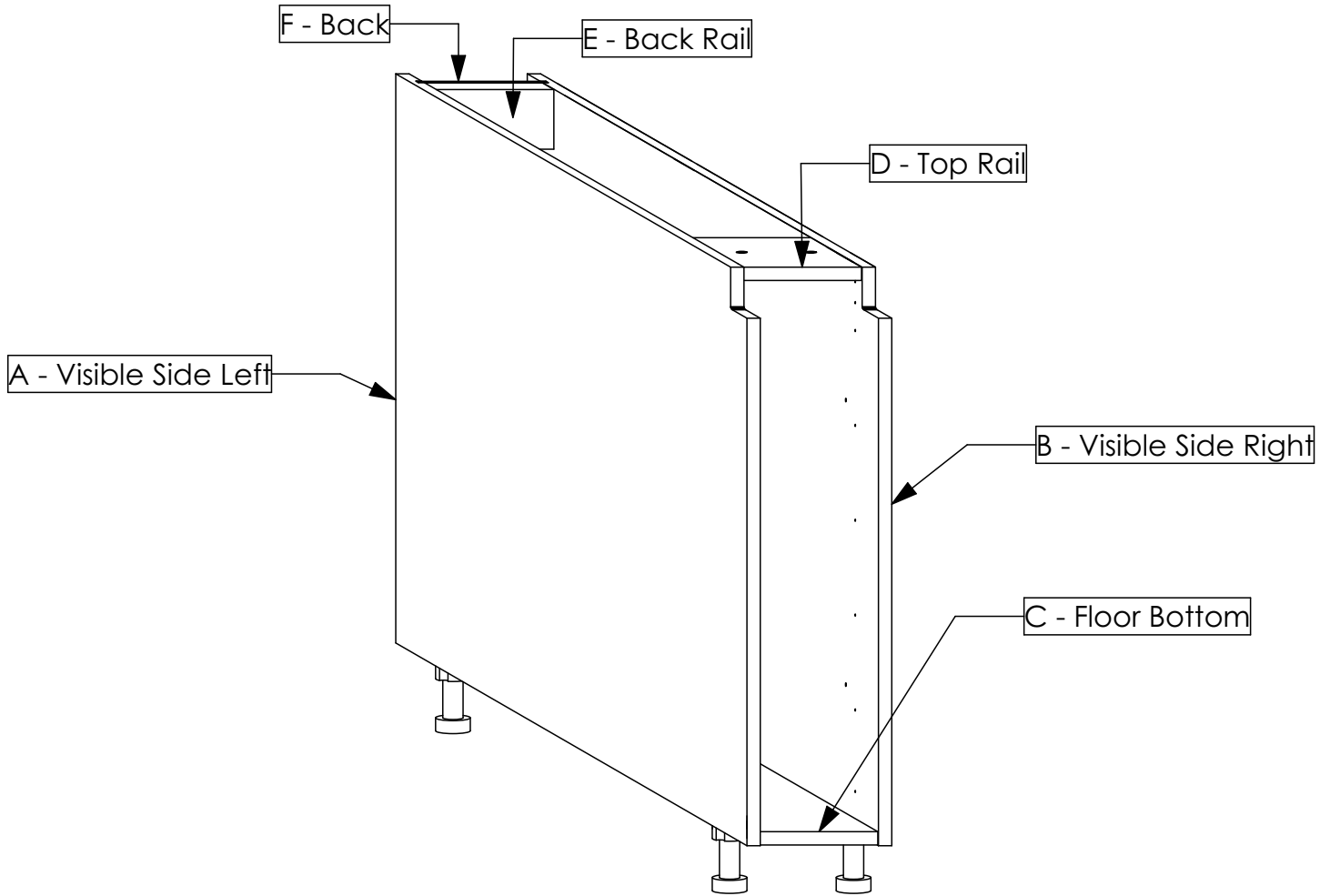





## ASSEMBLY GUIDE

### BASE CABINET 200mm



**TOTAL NUMBER OF PANELS: 6**

#### HARDWARE

PRODUCT	QTY	IMAGE
Dufix	8	
Minifix	8	
Wooden Dowel	16	
Screw 3.5 x 16mm	18	
Plinth Leg With Base H100mm Kit	4	
Cabinet Connecting Screw Kit	4	

# TOOLS REQUIRED



Screw Driver  
(Pozi Drive Head)

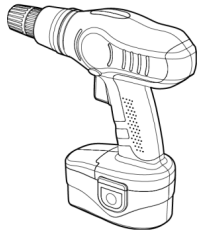

Cordless Drill

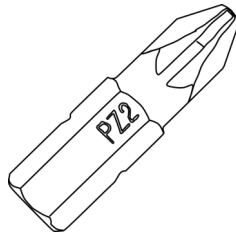

Pozi Bit (PZ2)

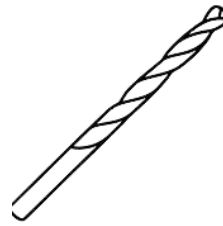

8mm Drill Bit



Rubber Mallet

## GENERAL INSTRUCTIONS

1. Confirm that all panels (6) are in the package before assembling.
2. Check the white sticker on each panel for the labelling (A, B, C, D, E & F).
3. Ensure that the panels are laid on a non-abrasive surface when assembling.
4. Note that all panel connections are done using the system described below.

## PANEL CONNECTION AND FASTENING

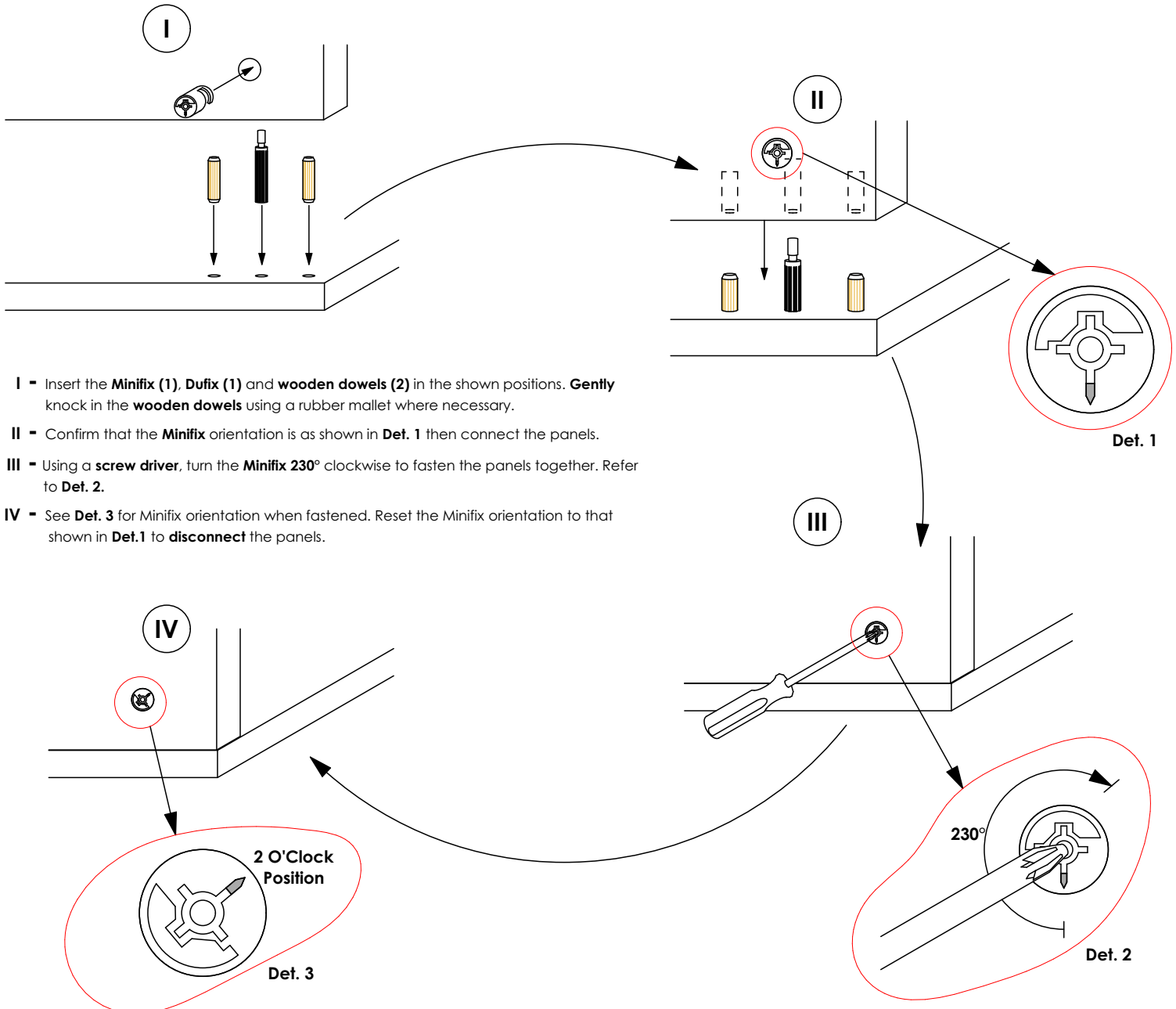

# PILOT HOLES GUIDE FOR SIDE PANELS

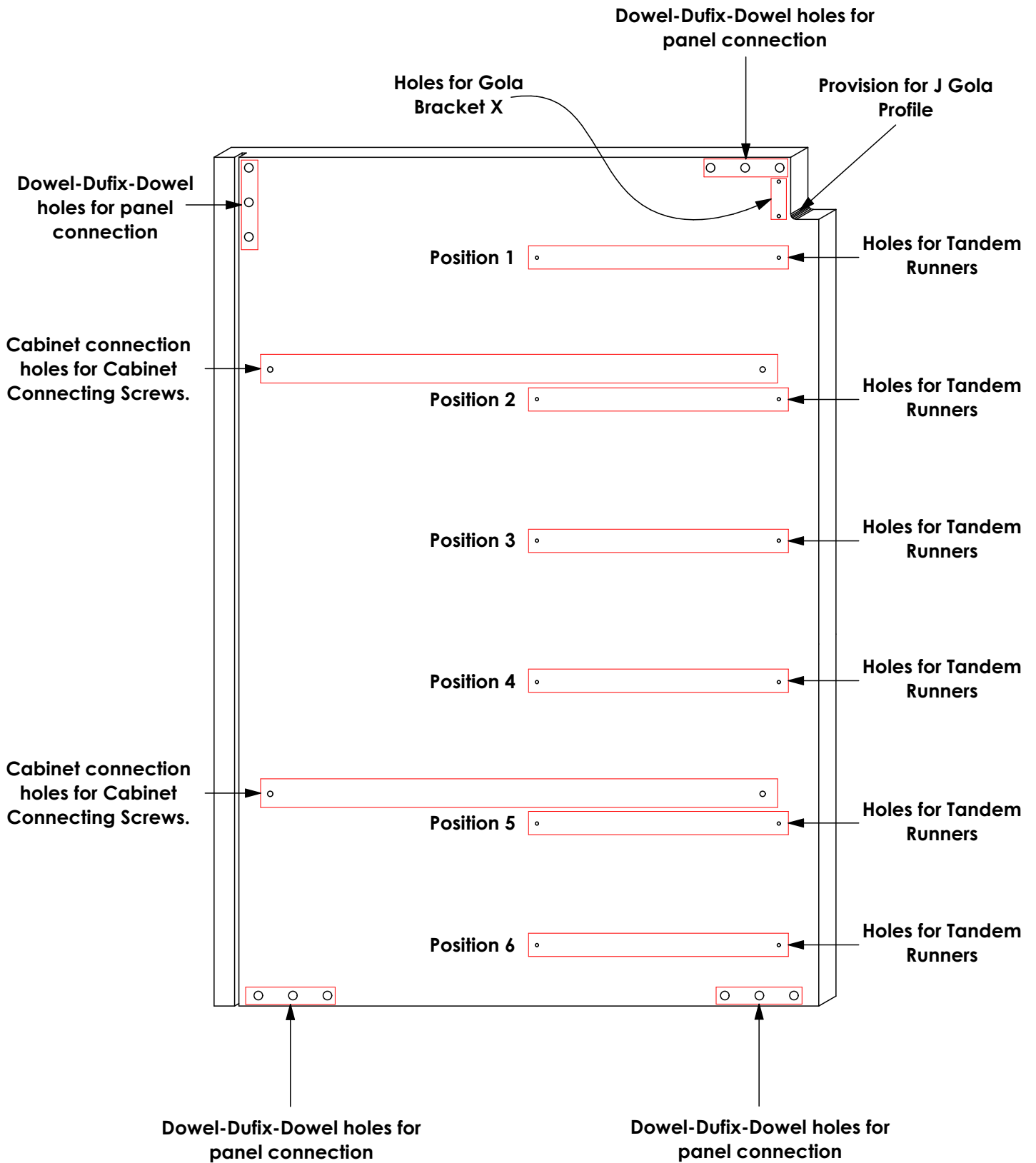

## STEP 1

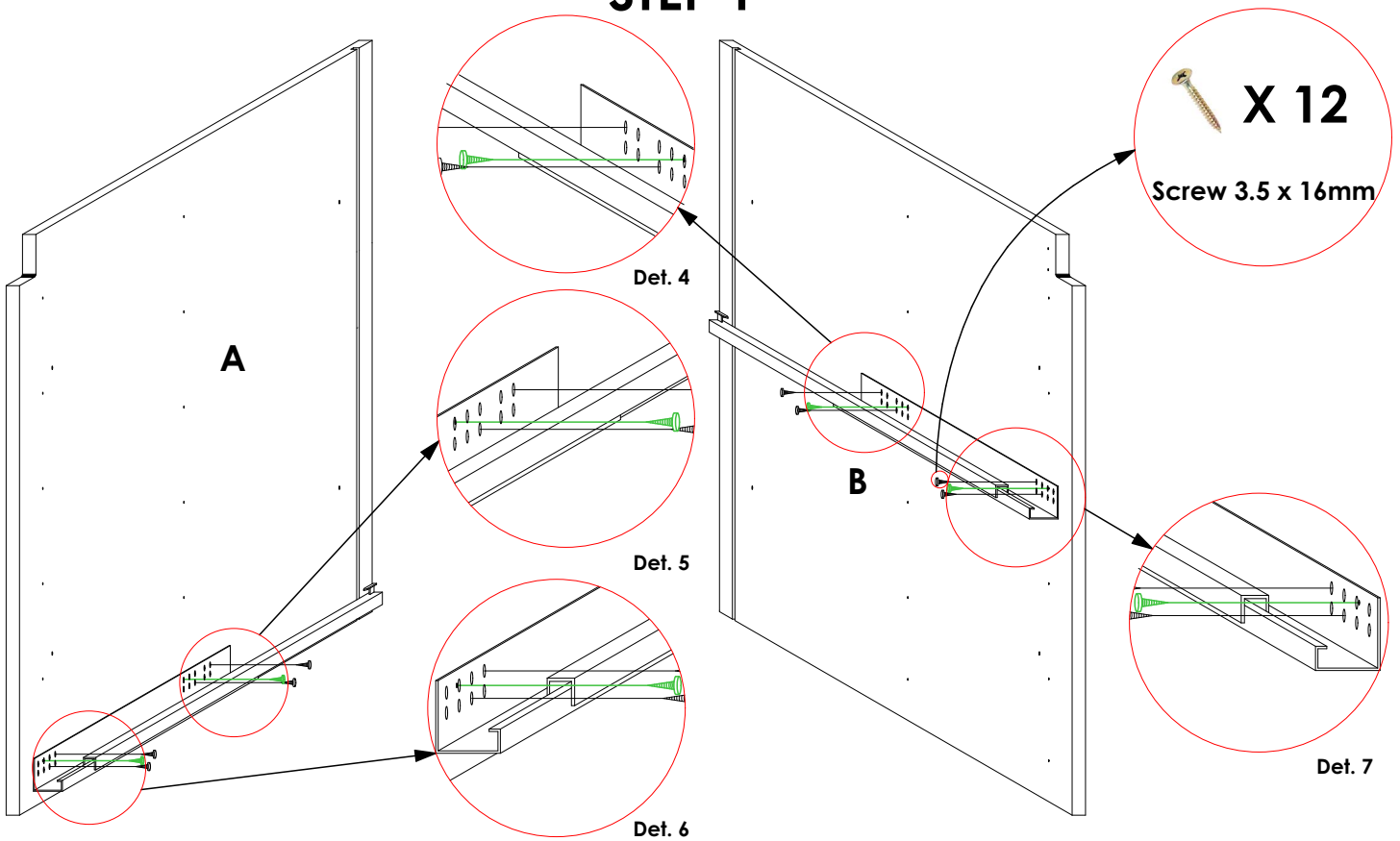

From the **Drawer boxes package**, remove the Tandem Single Extension **runners** and connect them to panels **A** and **B** as shown (**Position 3** on Panel **B** and **Position 6** on panel **A**. See **Pilot Holes Key**). First, align the screws (**3.5 x 16mm**) marked green with the shown holes on the runners and the pilot holes on panels **A** and **B** (See **Det 4-7**). This will ensure the correct positioning of the runners. Reinforce the runners by adding screws in the shown positions.

## STEP 2

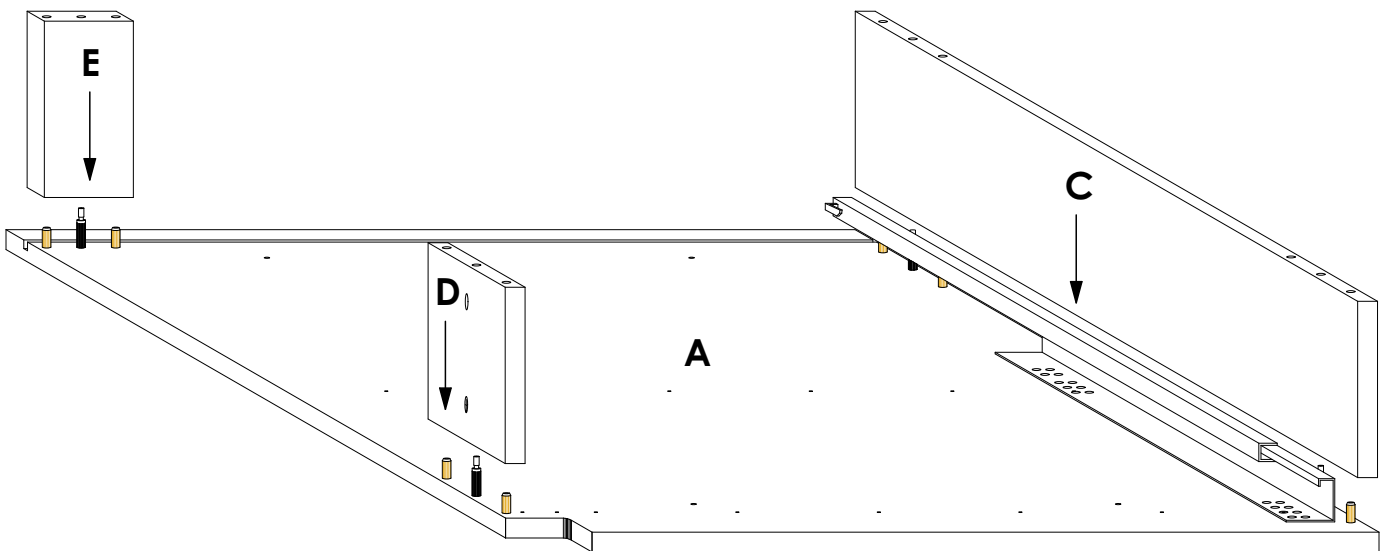

Connect panels **C, D & E** to panel **A** as shown. Refer to the holes and/or grooves on the diagram to determine the panel orientation.

## STEP 3

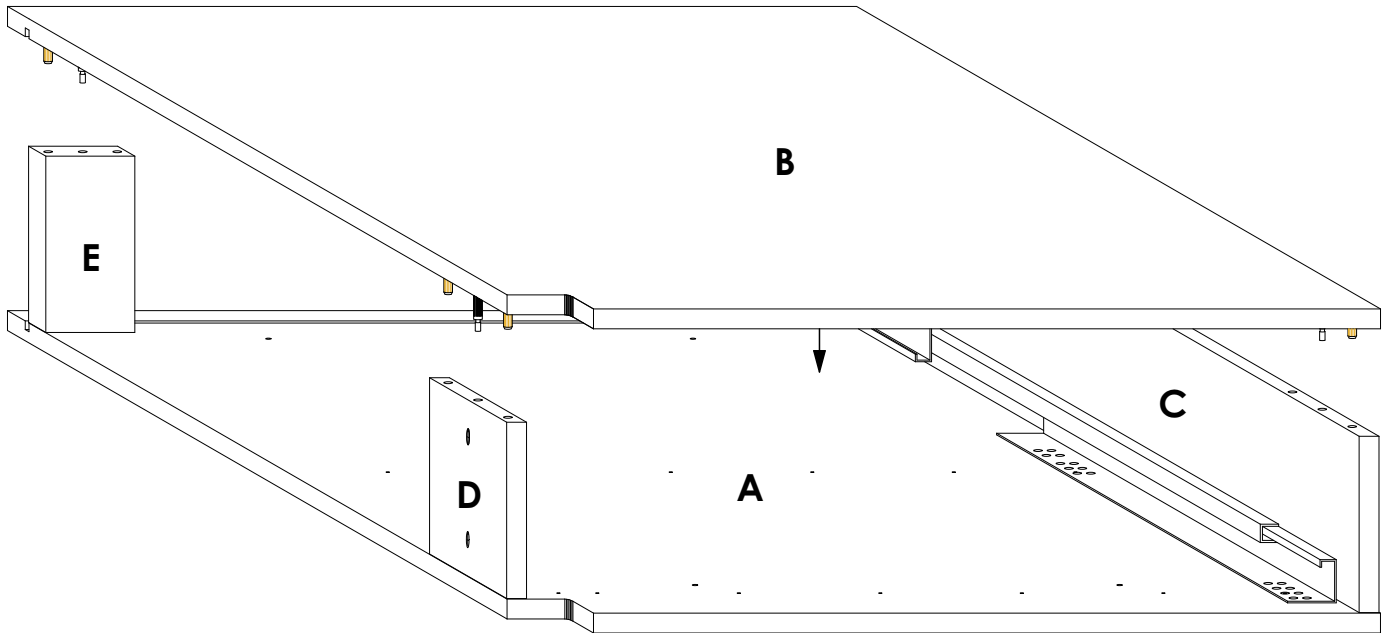

Connect panel **B** to panels **C, D & E** as shown. Refer to the holes and/or grooves on the diagram to determine the panel orientation.

## STEP 4

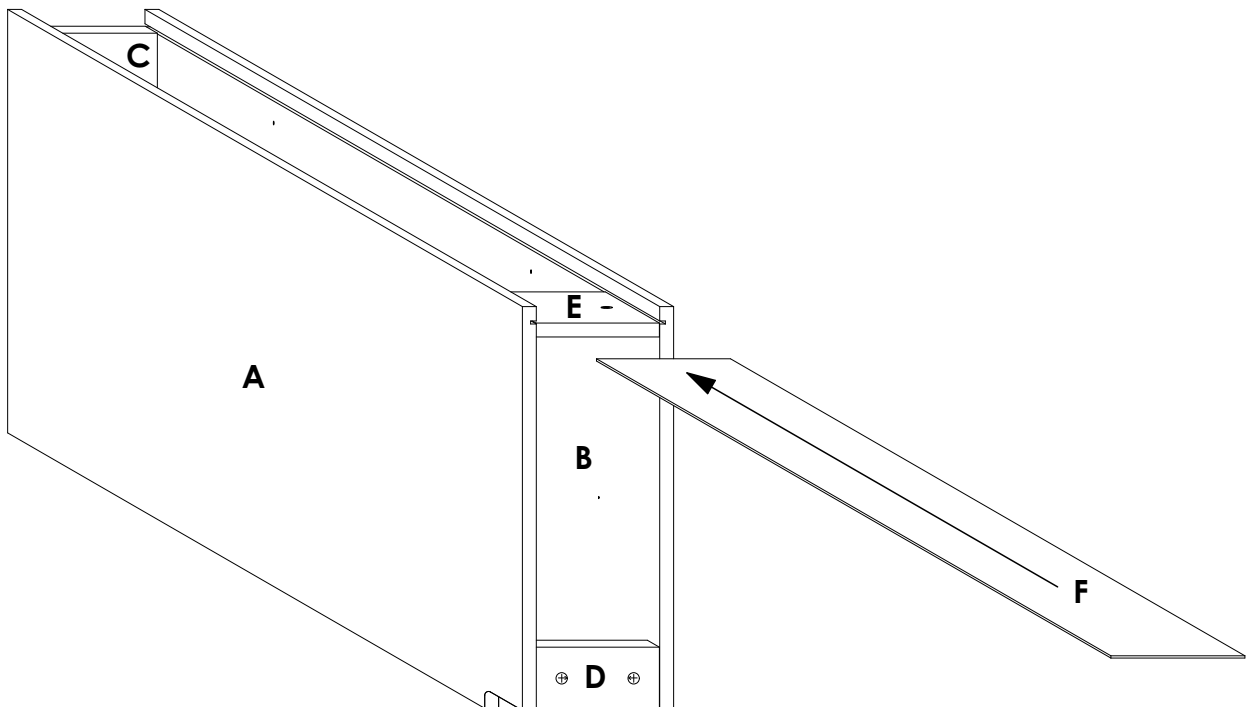

Slide the 3mm panel (**F**) into the groove on panels **A & B** with the finished side facing down. Refer to the holes and/or grooves on the diagram to determine the panel orientation.

## STEP 5

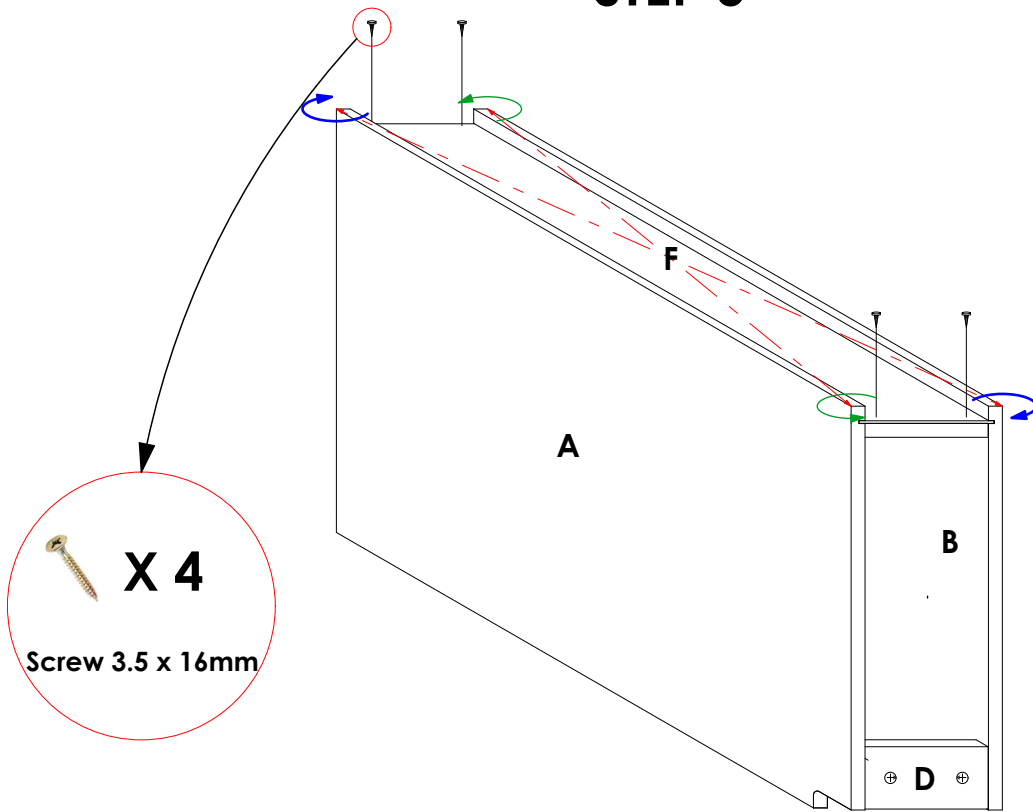

First, **check the diagonal** of the cabinet by measuring the two distances indicated by the red, broken lines. They should be equal. If not, twist the cabinet accordingly in the diagonal corners as shown until an equal value is achieved. After, secure panel **F** to panels **C & E** as shown using **Screw 3.5 X 16mm**.

## STEP 6

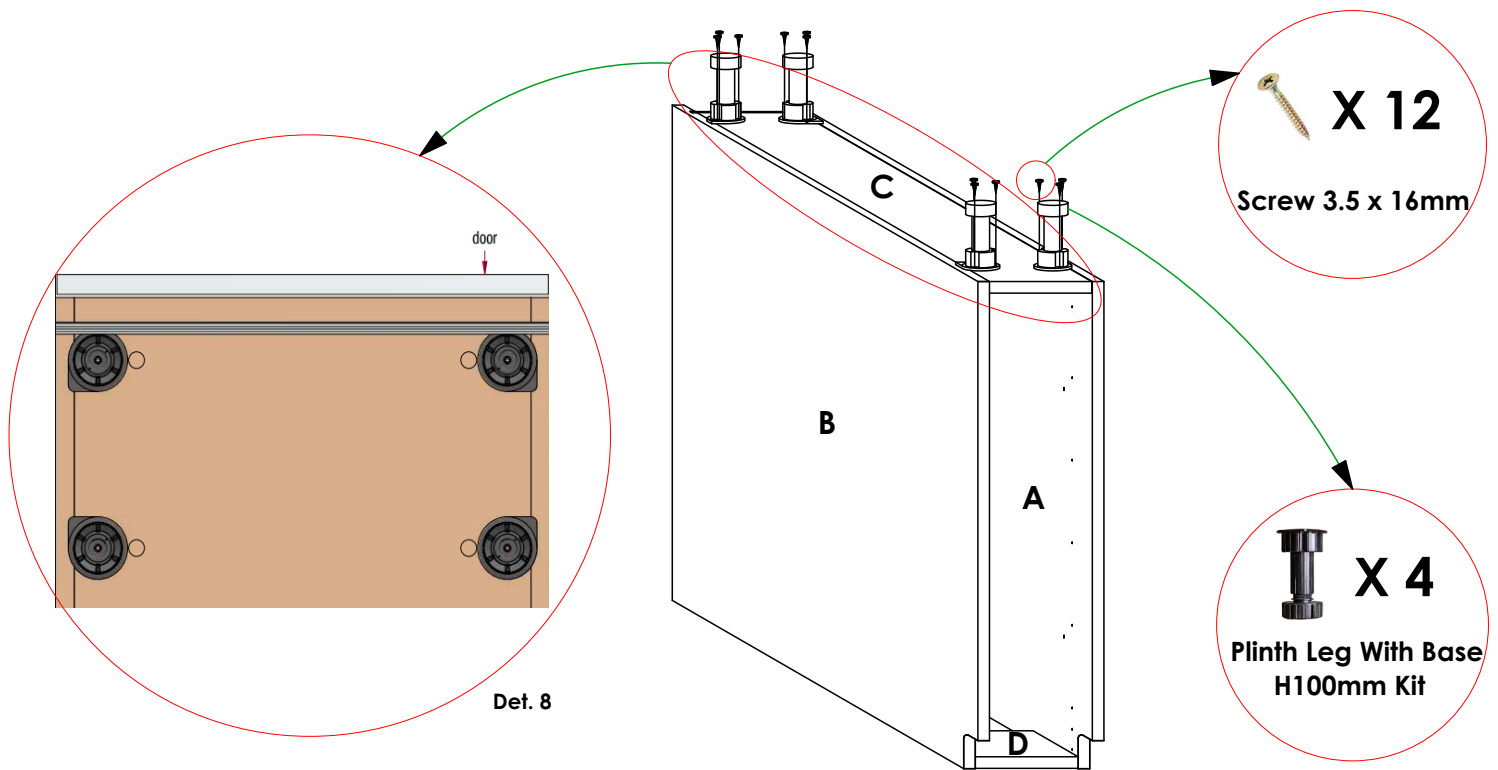

Flip the cabinet up-side down as shown. Place the four units of **Plinth Leg With Base** in the shown positions, aligning with the pre-drilled pilot holes on panel **C**. Ensure that the orientation is as shown in **Det. 8**. Using **Screw 3.5 X 16mm**, secure the legs onto panel **C**.

## STEP 7 (GOLA PROFILE INSTALLATION)

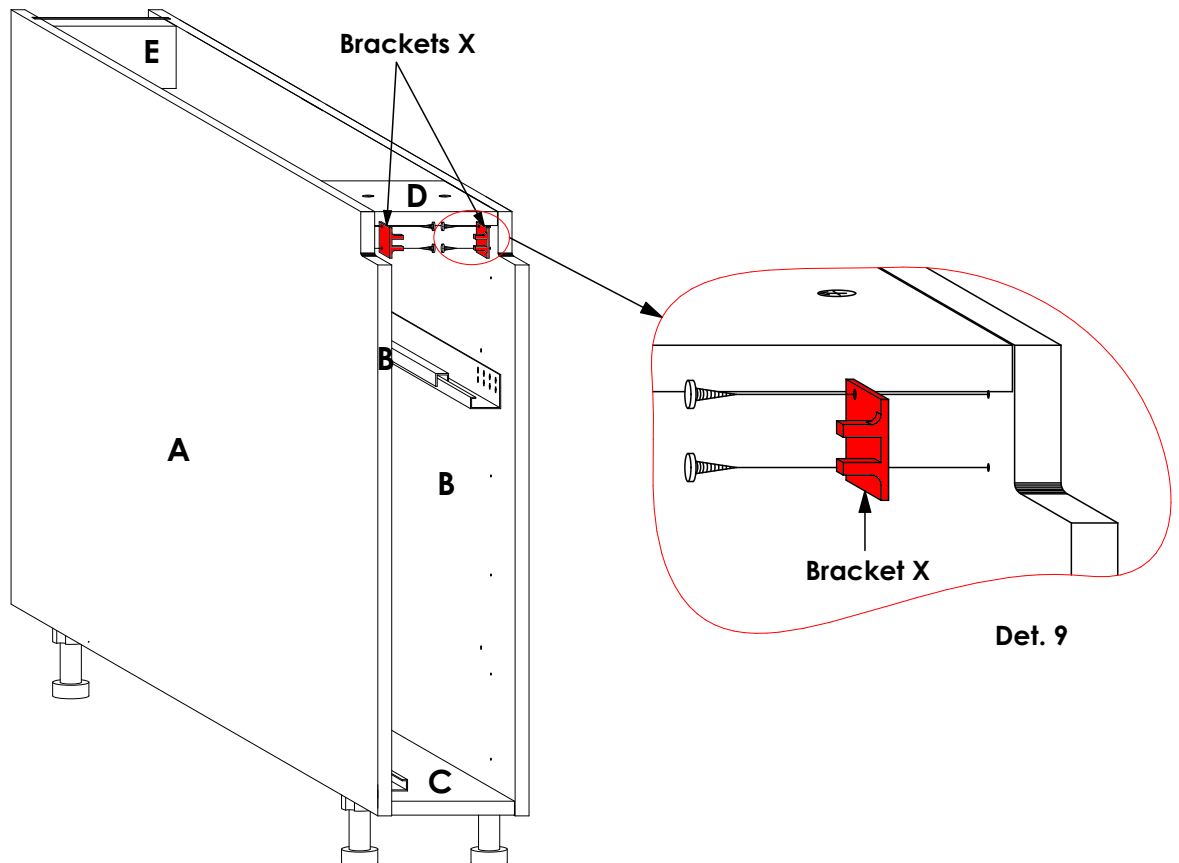

Using **Screw 3.5 x 16mm**, connect the shown **Brackets X** on panels **A & B** as shown. Use the pre-drilled pilot holes to align the brackets. See **Det. 9**.

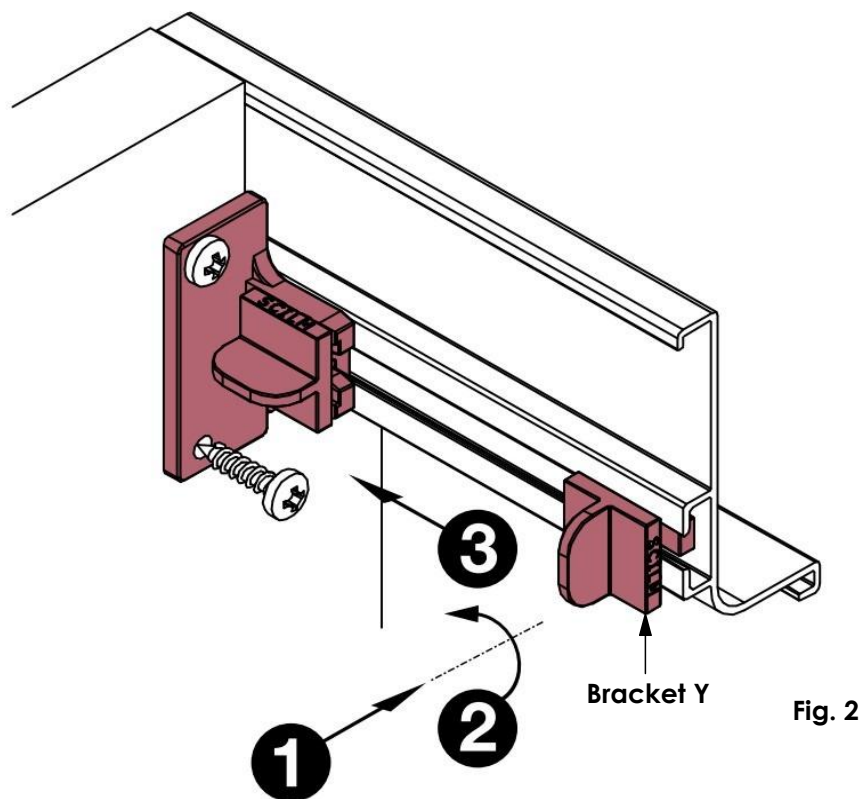

1. Place the Gola Profile on the provided notch as shown. Insert **Bracket Y** in the channel on the backside of the Gola Profile. See **Fig. 2**.
2. Turn **Bracket Y** 90° as shown. See **Fig. 2**.
3. Slide **Bracket Y** onto **Bracket X** as shown. See **Fig. 2**.

See the Door Installation guide for further instructions.

## STEP 8

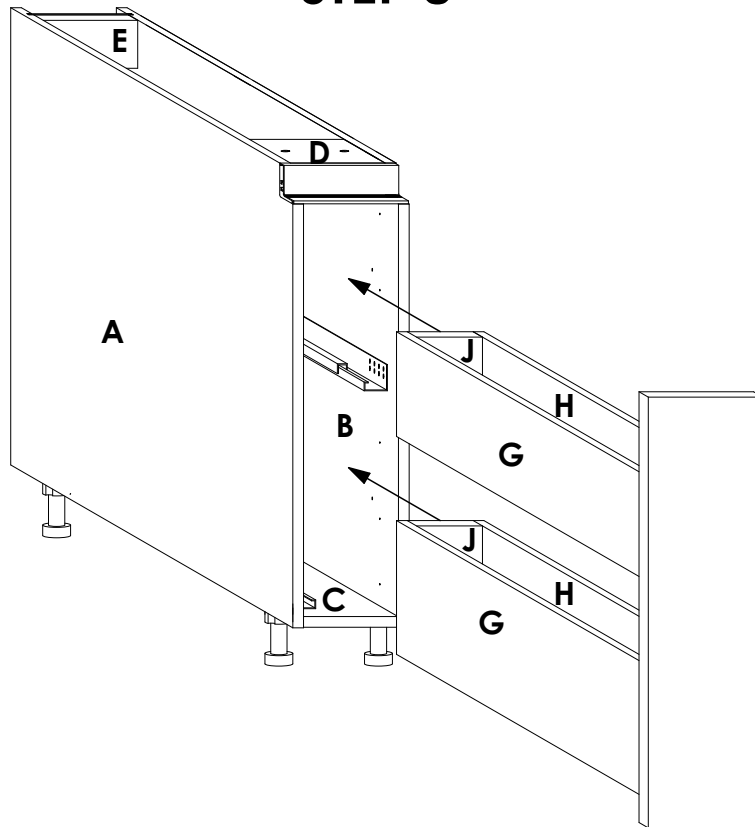

Insert the Drawer Boxes as shown. Push the drawers all-in ensuring that the **locking device** snaps into the **Tandem Single Extension runners** and that the **hook** at rear end of the runners enters the **holes** at the **back of panel J**. If the holes are too small for the hook, expand them using a **6mm** drill bit.

## STEP 9

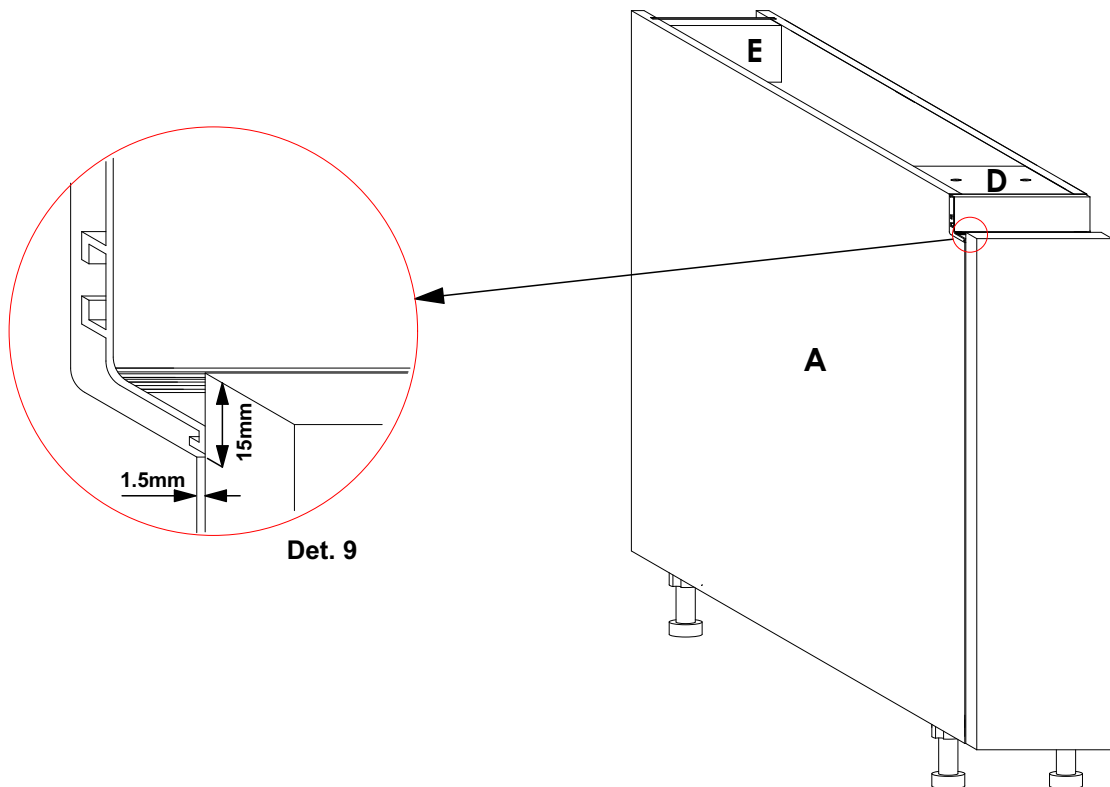

Adjust the **drawer face** to achieve the clearances shown in **Det. 9**. This is done by gently knocking the drawer face in the desired direction until the clearances in **Det. 9** are attained. When done, reinforce the Drawer Boxes-Drawer Face connection by adding **Screws 4.0 x 30mm** in the remaining holes on panels **F** of the Drawer Boxes.